

# Top Down Design

**Top-Down Design** is a methodology that starts at the highest level of a design concept and proceeds towards the lowest level. You start with the broad project specification in mind and put that information in a centralized location. Then you progress from this information to the individual parts. This makes it easy to design and manage large product assemblies. You can make changes from a central location that will propagate to all levels of the design

Pro/ENGINEER provides us very powerful Top-Down Design tools. If implemented properly, multiple design teams and designers can work on a project concurrently and communicate design data easily and quickly, with full confidence that all components will fit seamlessly into the final product.

**Top-Down Design Tutorials** have been developed to teach a user all the tools, Pro/ENGINEER provides for implementing the Top-Down design. The self-study course starts from the very basic concepts and teaches advanced concepts step by step. After completing these tutorials an Engineer or Designer will be able to start a real-world design project from concept and progress it to complete 3D definition. The tutorials are written not only from software point of view but great emphasis has been laid on the implementation of the top-down design methodology to real products.

The training material is divided into sections. Each section is accompanied with exercises to practice the concepts learned. CAD models are accompanied for the user practice. Finished models are also supplied to compare the work done by the user.

Please click on the topic name to view more details.

1. [Introduction](#)
2. [Product Designing](#)
3. [External References](#)
4. [Managing External References](#)
5. [External Copy Geometry](#)
6. [Multi-Level Assembly](#)
7. [Skeletons And Motion](#)
8. [Family Table Of Skeleton](#)
9. [Layouts](#)
10. [Derivative Models](#)
11. [Conclusion](#)

## Prerequisites

The user should have basic concepts in the following

- 1) Solid Modeling
- 2) Surface Modeling
- 3) Assembly

## Stats

Following are the stats for WF 5.0

Total Pages: **543**

Total Exercises: **28**

# INTRODUCTION

This chapter will describe the Top-Down Design methodology and available tools in Pro/ENGINEER to accomplish this. It also compares the Top-Down design with Bottom-Up design technique.

Typical workflow of Top-Down Design will be explained in theory and also with the help of practical examples.

## EXERCISE 1

In this exercise we will learn how to create a simple assembly of parts that are driven by skeleton model.

The topics covered are as follows.

- ❖ Creating Skeleton
- ❖ Assembling the components
- ❖ Using Copy Geometry feature to communicate references
- ❖ Creating model geometry

We will see how to achieve the following goals for the shown assembly of components.

- ❖ Both components should be equal in length and width
- ❖ The shape of the mating surfaces should be same
- ❖ There should be two holes in each component; the diameter of holes should be same and their axis aligned.

## EXERCISE 2

In this exercise we will create a simple housing consisting of two parts.

The topics covered are as follows.

- ❖ Understanding what geometry needs to be created in Skeleton model
- ❖ Using Publish Geometry and Copy Geometry features to communicate references
- ❖ Creating model geometry by using references copied from skeleton
- ❖ Creating Interlock details in both components driven by geometry in skeleton

We will see how to achieve the following goals for the shown assembly of components using TDD.

- ❖ Profile of both components should be same
- ❖ Two rectangular holes in the side walls of the components should be aligned and of same width.

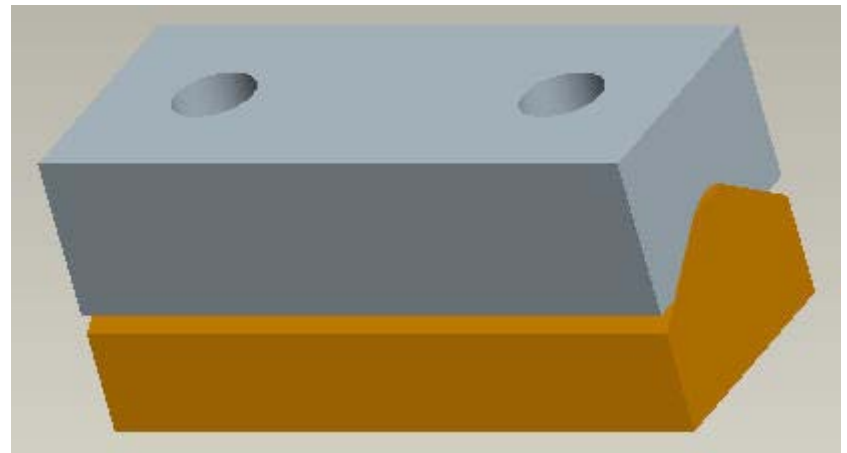

Assembly of Finished Components

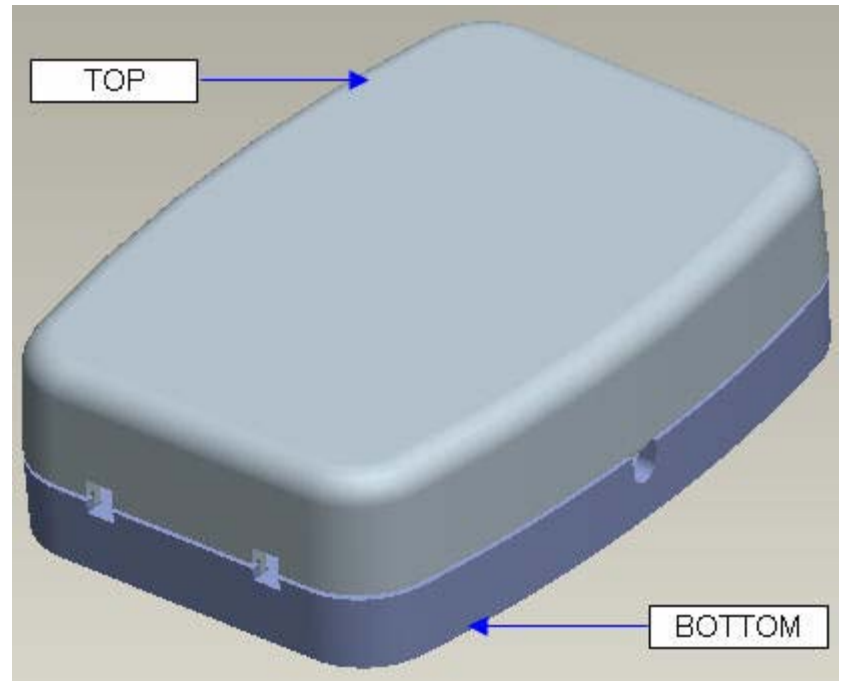

Assembly of Finished Components



Cross-Section of Assembly showing Interlock Details

# PRODUCT DESIGNING

In this section we will go through the basic steps of developing plastic products using Top-down design methodology.

The focus of the exercises covered in this section is the good understanding of the top-down design methodology. We will develop the products with the Pro/E tools learned in previous section. Here we will emphasize the top-down design concept and not the tools that Pro/E offers. In this way the reader will develop a strong interest in this design approach and will follow the remaining chapters vigorously.

## EXERCISE 1

In this exercise we will create a plastic product consisting of three parts

The topics covered are as follows.

- ❖ Analyzing requirements of the product assembly and deciding what geometry needs to be created in Skeleton model
- ❖ Building Split Surface, the surface where two components of a product join, when the components join along 3-D surface
- ❖ Considering the manufacturing constraints while creating geometry in skeleton

We will see how to achieve the following goals for the shown assembly of components using TDD.

- ❖ Profile of the TOP and BOTTOM parts, forming the housing, should be same and both components join along a 3-D surface
- ❖ Profile of LED COVER and accommodating cut in the TOP part should be same and outer shape of both parts follow a common surface

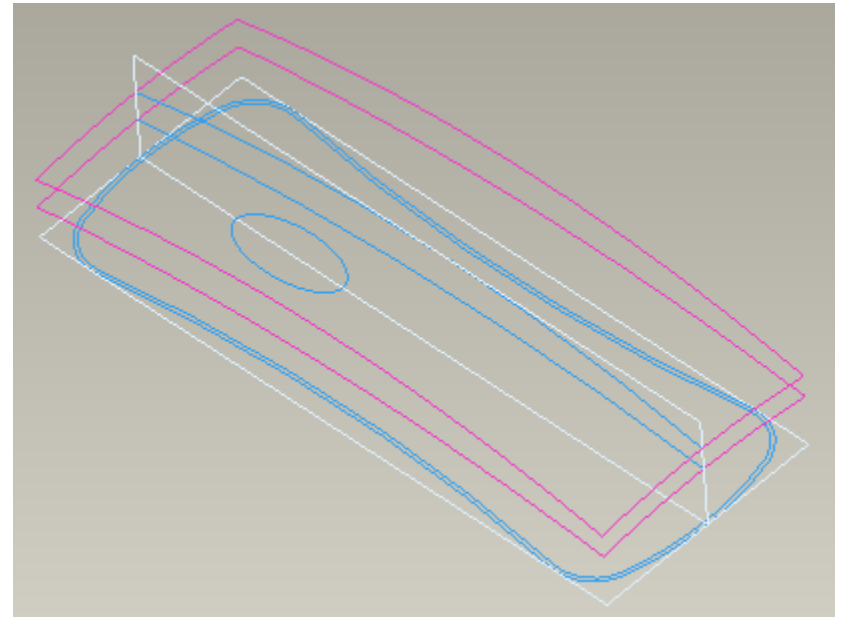

Skeleton Model

Showing geometry that will be shared by multiple components

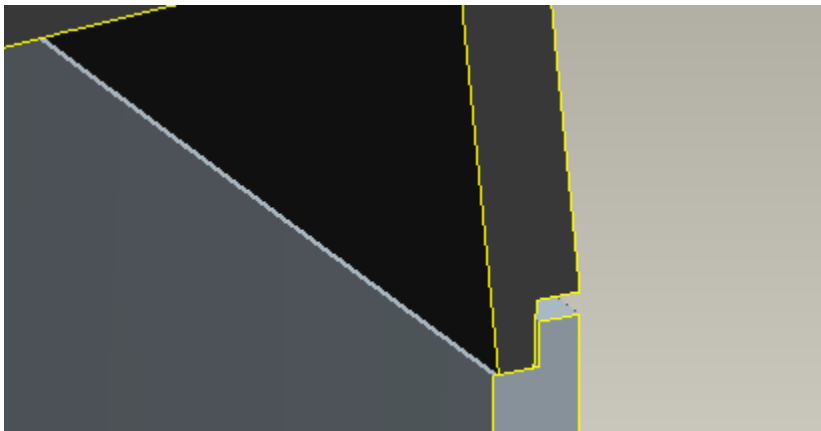

Cross-Section of Assembly showing Interlock Details

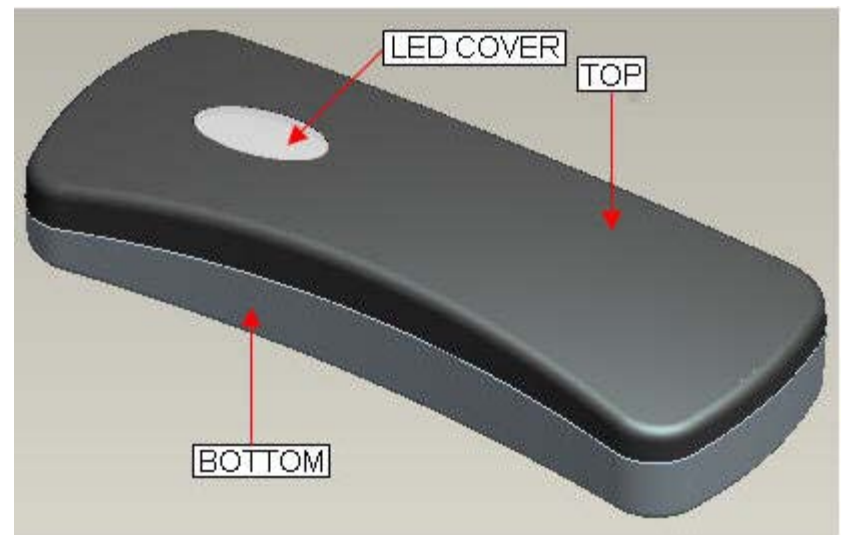

Assembly of Finished Components

## EXERCISE 2

In this exercise we will create a plastic housing for a remote-control consisting of four parts

The topics covered are as follows.

- ❖ When should a designer define the complete skin of a product in skeleton
- ❖ When should a designer apply drafts and rounds to the geometry in skeleton
- ❖ What geometry should not be created or merged in skeleton
- ❖ Using the surfaces copied from the skeleton model to create solid geometry in components

We will see how to achieve the following goals for the shown assembly of components using TDD.

- ❖ Profile of the TOP and BOTTOM parts, forming the housing, should be same and both components join along a 3-D surface
- ❖ The elliptical cut at the front side should be of same size and shape in both parts.
- ❖ Profile of BATTERY COVER and accommodating cut in the BOTTOM part is same and the outer shape of both parts (including underside and side) follow common surfaces
- ❖ The round value is same for both parts

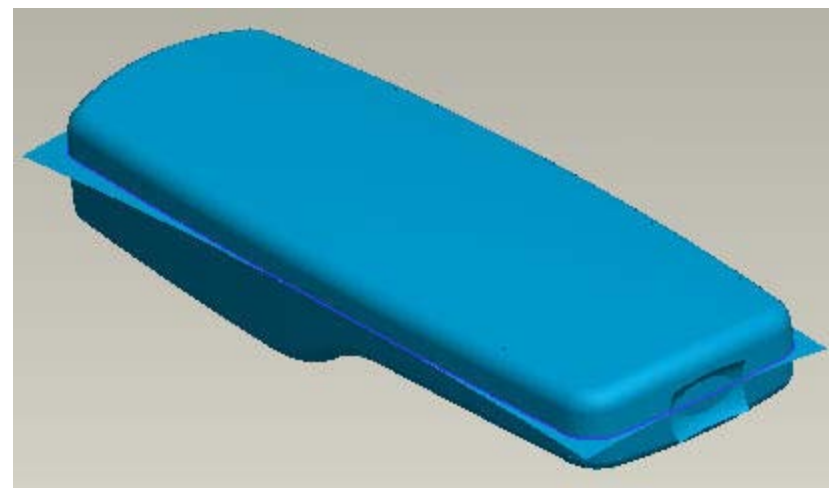

Skeleton Model  
Showing complete skin, split surface and elliptical-cut surface

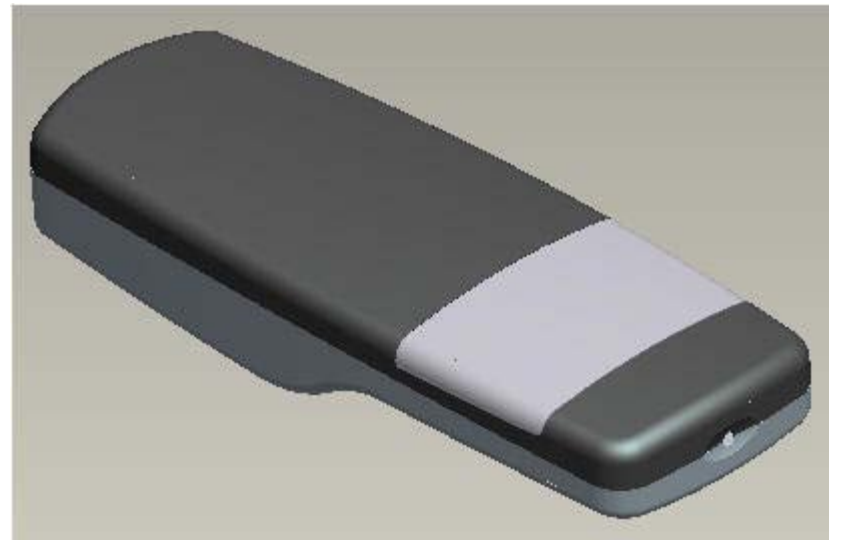

Assembly of Finished Components

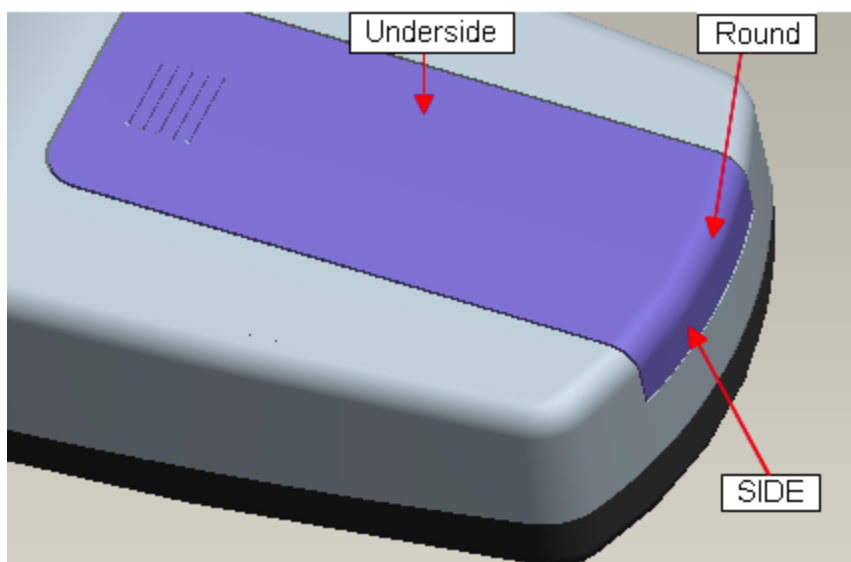

BOTTOM and BATTERY COVER Components

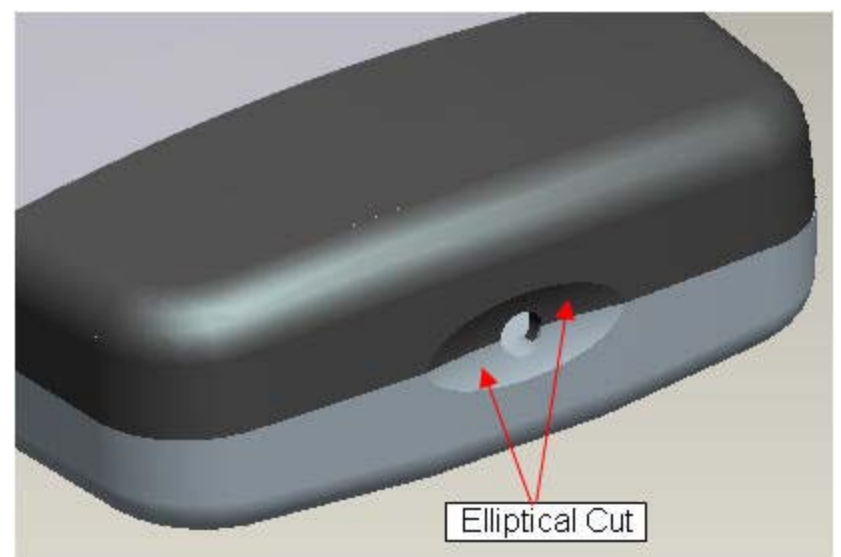

Details of Emitter Hole and Elliptical cut

## EXERCISE 3

In this exercise we will create a plastic housing for a mobile phone consisting of three parts

The topics covered are as follows.

- ❖ Defining the skin of the product by using advanced surfacing techniques
- ❖ Building the drafts into the surfaces that define the body shape
- ❖ How to implement TDD for products having non-uniform thickness
- ❖ When should a designer define the complete skin of a product in skeleton
- ❖ Using surfacing techniques to hollow out parts having non-uniform thickness .

We will see how to achieve the following goals for the shown assembly of components using TDD.

- ❖ Profile of the TOP and BOTTOM parts, forming the housing, should be same and both components join along a 3-D surface
- ❖ Profile of LCD COVER and accommodating cut in the TOP part is same and outer shape of both parts follow common surface
- ❖ The round surfaces are shared by both (LCD COVER and TOP)

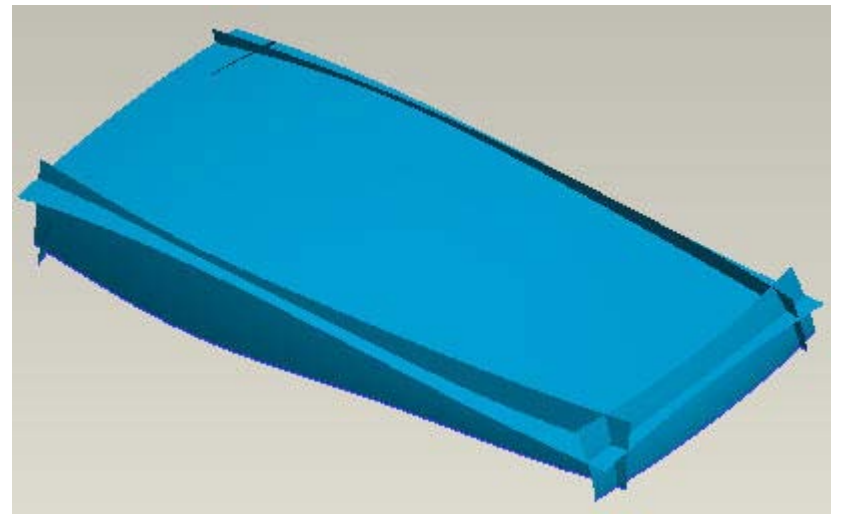

Incomplete Skeleton Model  
Showing side and top surfaces



Assembly of Finished Components

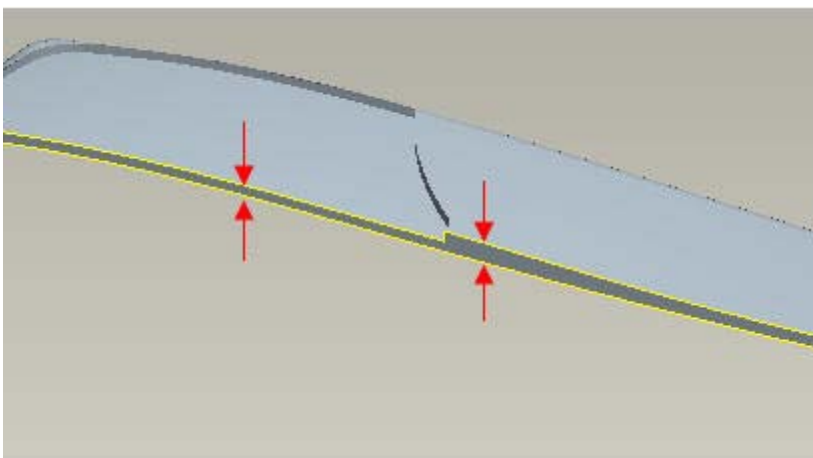

Component with Non-Uniform Thickness

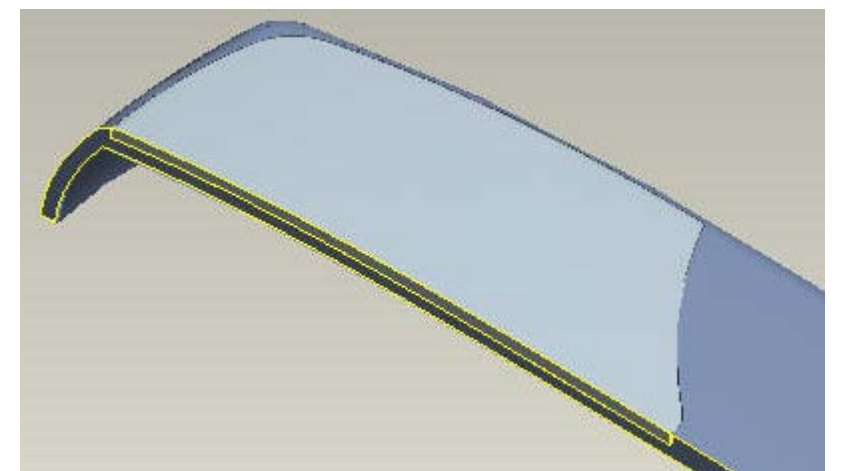

Cross-Section of Assembly

# EXTERNAL REFERENCES

When a feature in a model is referencing some geometry or information in any other model then such reference is called “External Reference”.

Generally, external references should be created only between a skeleton and a given model. External references between any other models are difficult to manage and should be avoided.

In this chapter we will see how to investigate the external references in a design project. We will look at the following tools that are used for external references investigation.

1. Global Reference Viewer
2. Reference Graph
3. Reference Information Window
4. Model Tree

## EXERCISE 1

The topics covered are as follows.

- ❖ How to investigate the external references using Global Reference Viewer and Reference Graphs.
- ❖ Filters Settings

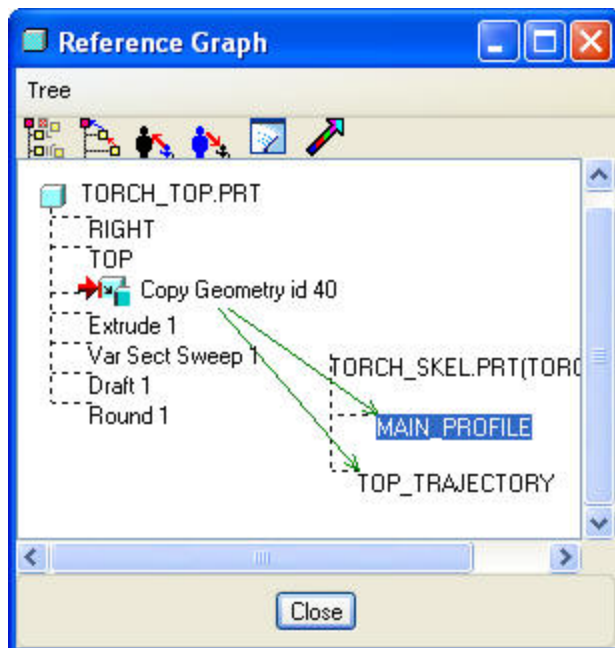

Reference Graph

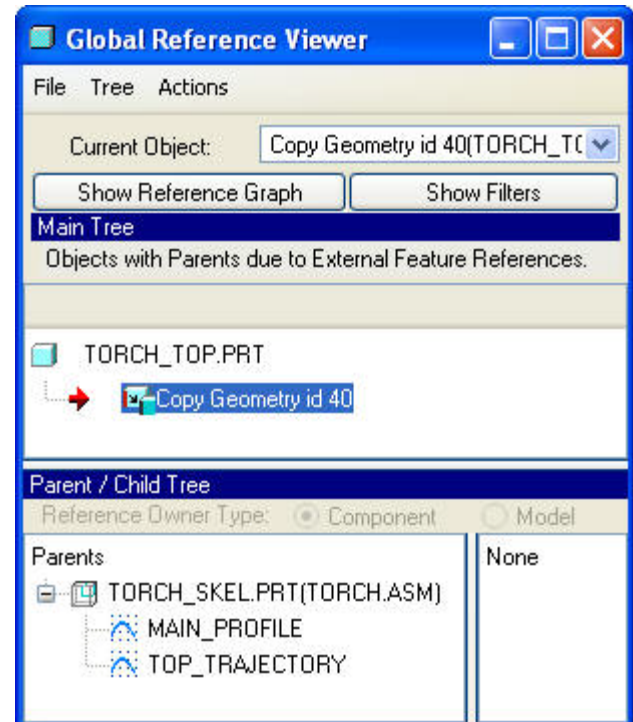

Global Reference Viewer

## EXERCISE 2

The topics covered are as follows.

- ❖ How to investigate the external references of a component when the parents are not in session.
- ❖ Adding a column to the model tree to see the status of Data Sharing Features

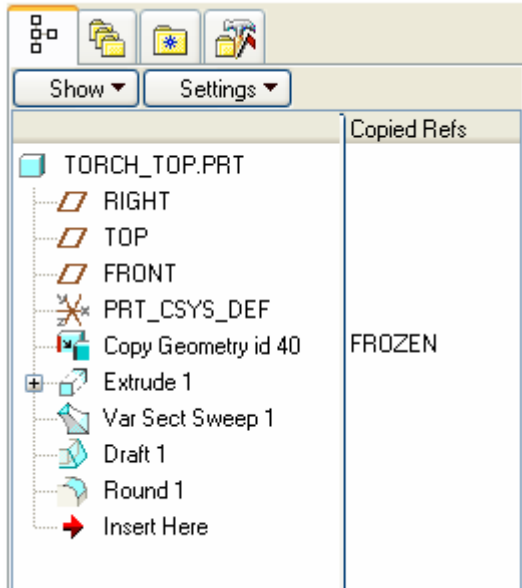

Showing status of Data Sharing Features

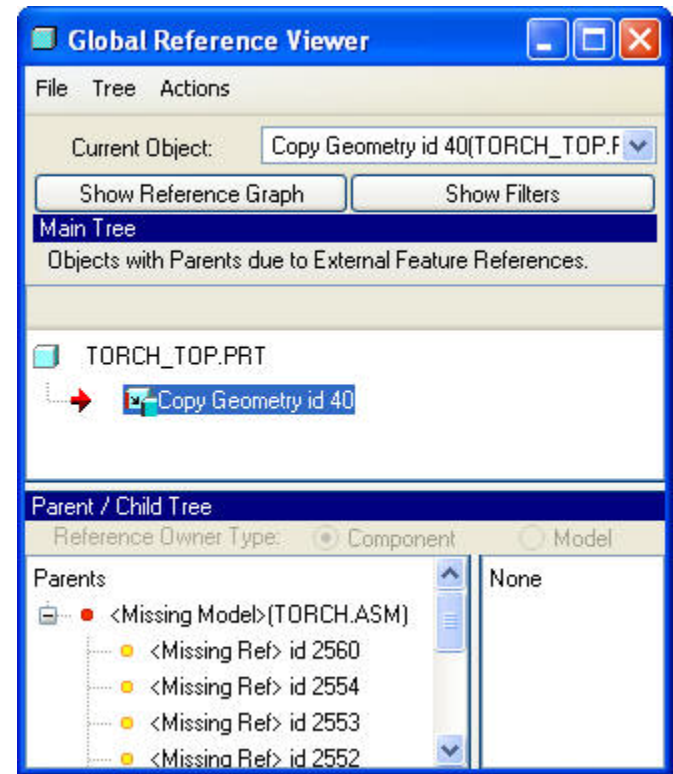

Global Reference Viewer-When the parents are not in session

## MANAGING EXTERNAL REFERENCES

External References (ER) are essential for a design project to ensure that components interface and fit together according to design intent. They make sure that models update automatically upon regeneration.

Generally, external references should be created only between a skeleton and a given model. External references between any other models are difficult to manage and should be avoided. If not managed properly external references may become bottleneck.

## EXERCISE 1

The topics covered are as follows.

- ❖ What is “Part to Part” referencing and why it is tempting
- ❖ Identifying and breaking the unwanted references
- ❖ Rerouting the references to skeleton

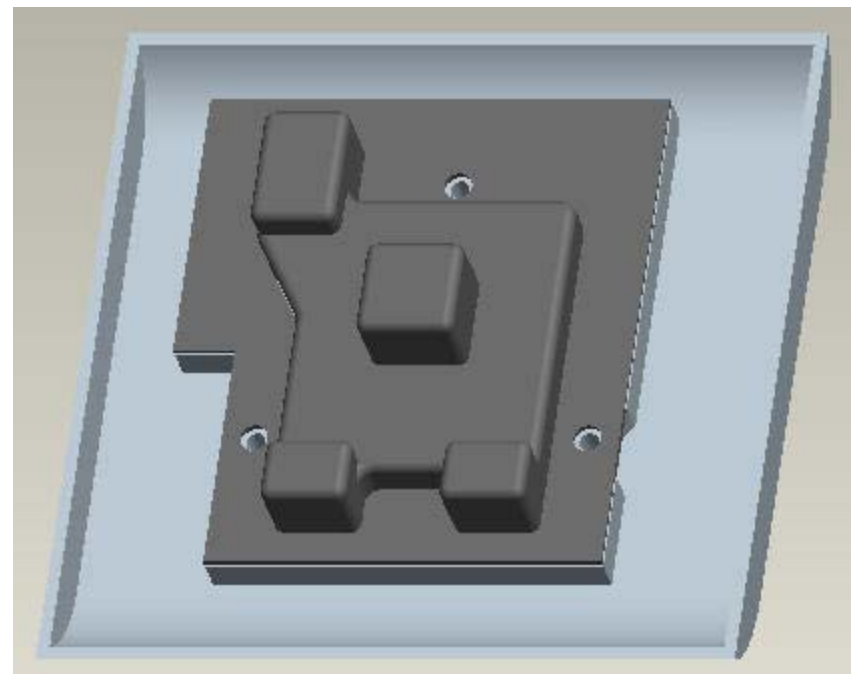

Assembly of Components

# EXTERNAL COPY GEOMETRY

The External Copy Geometry (ECG) functionality copies geometry from model to model without copying the geometry in the context of the assembly. Dependency on the assembly and all models along the path between the two components is avoided.

In this chapter we will see the differences between Internal Copy Geometry Feature and External Copy Geometry. We will also learn different methods of creating ECG feature.

## EXERCISE 1

The topics covered are as follows.

- ❖ The basic difference between a Copy Geometry and External Copy Geometry Feature.
- ❖ Converting an Internal Copy Geometry feature to External Copy Geometry

## EXERCISE 2

The topics covered are as follows.

- ❖ Creating an External Copy Geometry feature in part mode
- ❖ What models should be in memory to regenerate a Copy Geometry and External Copy Geometry Feature
- ❖ Determining the dependency on parts and assemblies along the path between a source and target component

## EXERCISE 3

The topics covered are as follows.

- ❖ How to create a reference pattern in a component by referencing a pattern in the skeleton model.

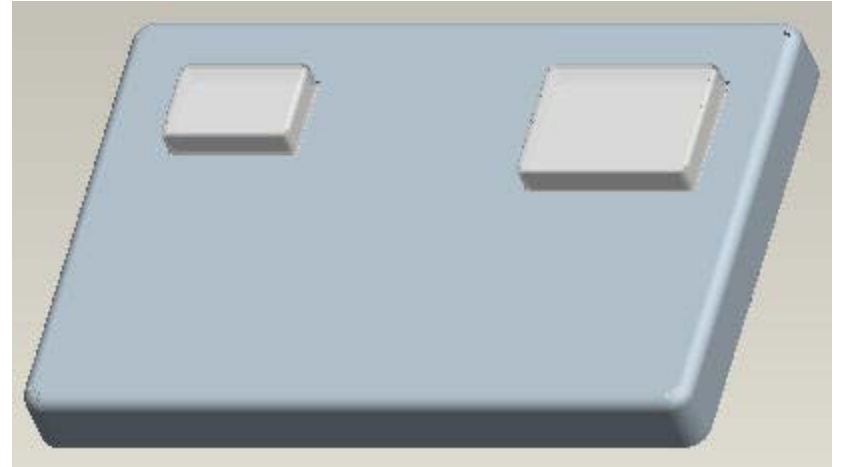

Assembly of Components

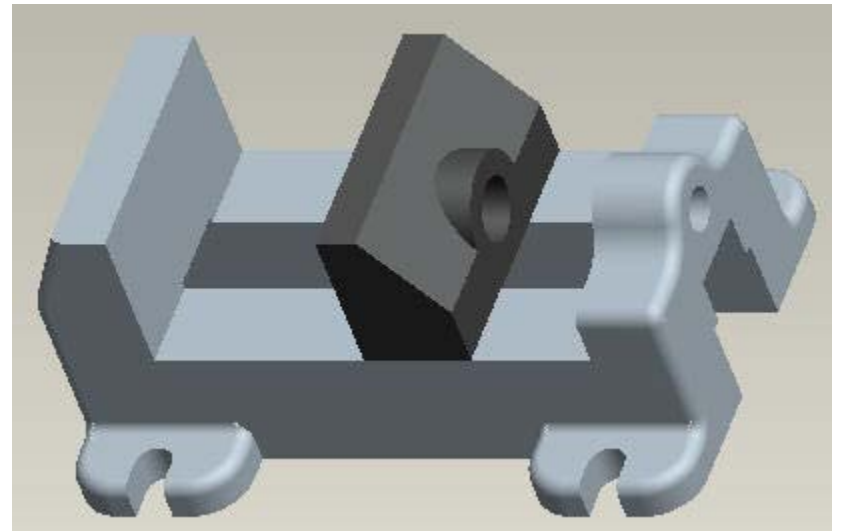

Assembly of Components



Skeleton Part Showing Pattern of Datum Points



Component Referencing the Pattern in Skeleton



# MULTI LEVEL ASSEMBLY

Multi-Level assemblies can be defined as the assemblies consisting of at least one or more sub-assemblies within main assembly.

In the previous chapters, we have seen how to implement top-down design for single-level assemblies. But now we will see the different approaches for implementing top-down design to multi-level assemblies.

We will explore following two approaches for the multi-level assemblies

1. Single skeleton
2. Multiple skeletons

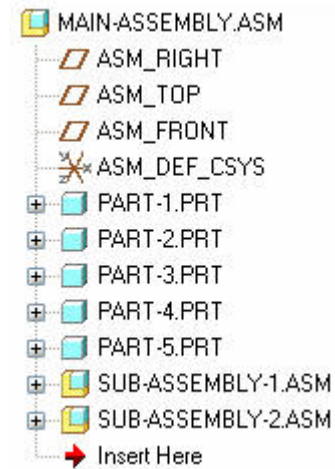

Example of a Multi-Level Assembly

## EXERCISE 1

The topics covered are as follows.

- ❖ How to implement top-down design to a multi-level assembly by using single skeleton for whole project
- ❖ Investigating External References in parts at different levels
- ❖ Understanding the pros and cons of copying references from the skeleton (located in main assembly) to the parts in the sub-assembly.

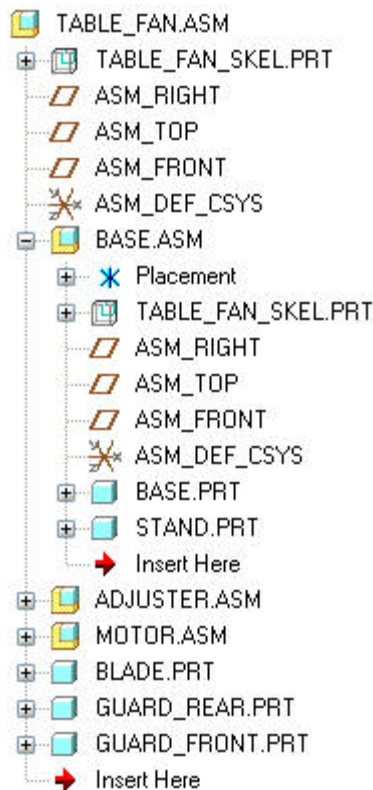

Assembly Structure: Showing Single Skeleton being used in main-assembly and sub-assembly

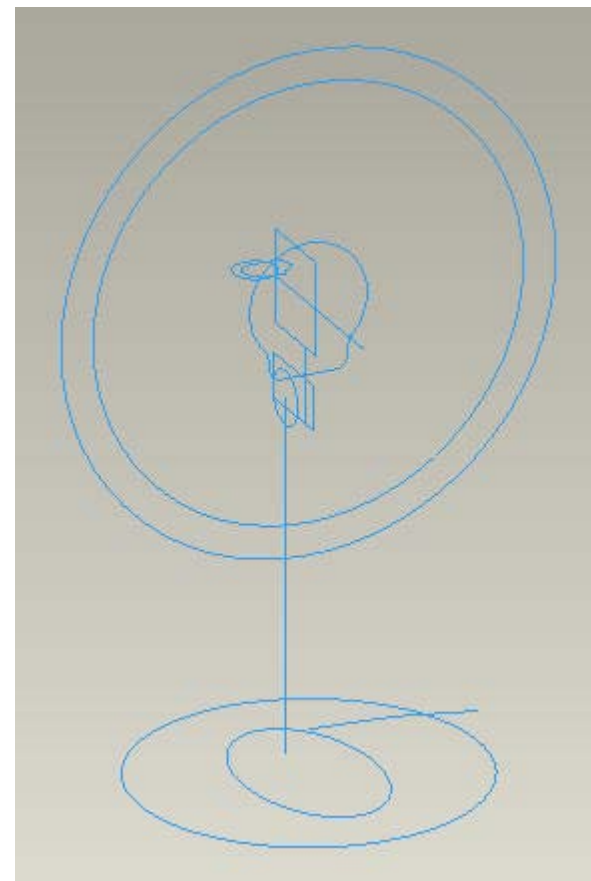

Skeleton Model

## EXERCISE 2

The topics covered are as follows.

- ❖ How to implement top-down design to a multi-level assembly by using a separate skeleton at each assembly level.
- ❖ Creating skeletons in sub-assemblies
- ❖ Communicating the design information from skeleton to skeleton
- ❖ Communicating the design information from skeleton to components
- ❖ Deciding either to define features in main skeleton or sub-assembly skeleton
- ❖ Investigating External References in parts at different levels

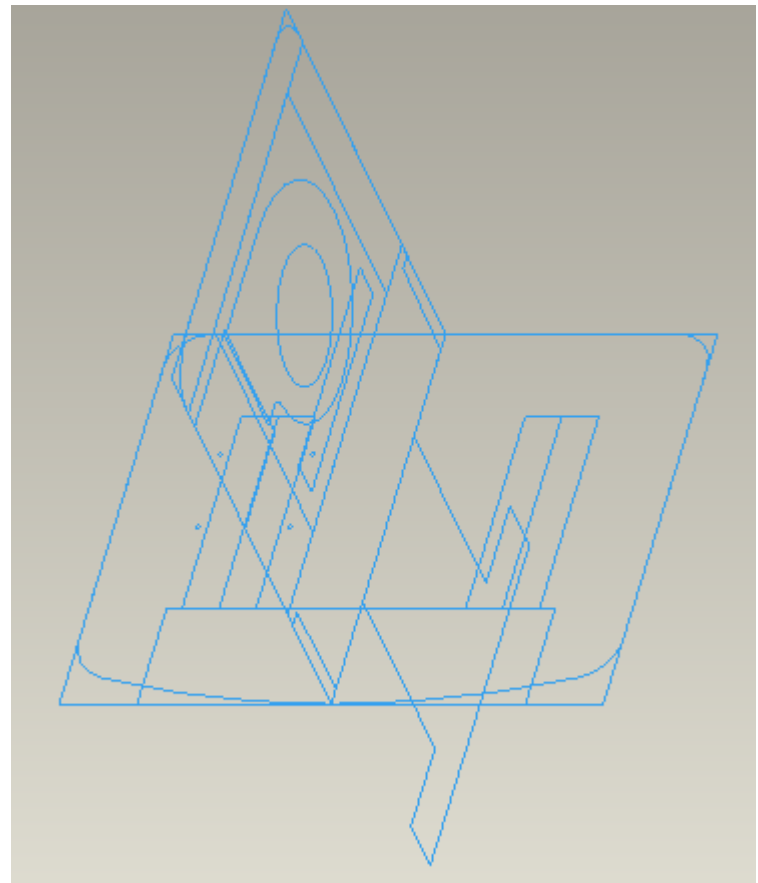

Main-Assembly Skeleton

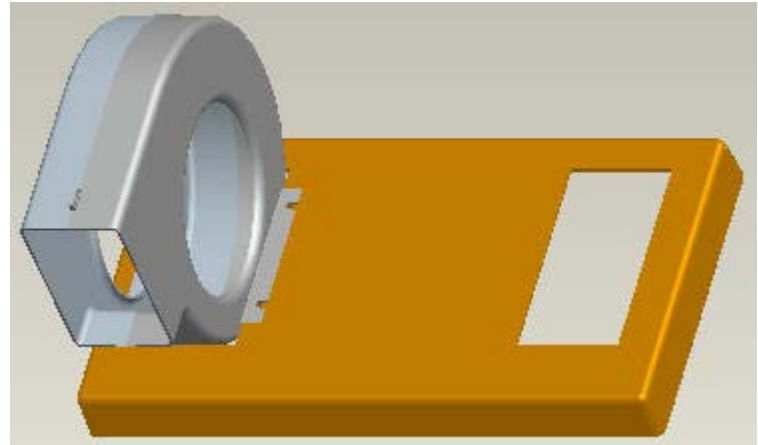

Assembly of Finished Components

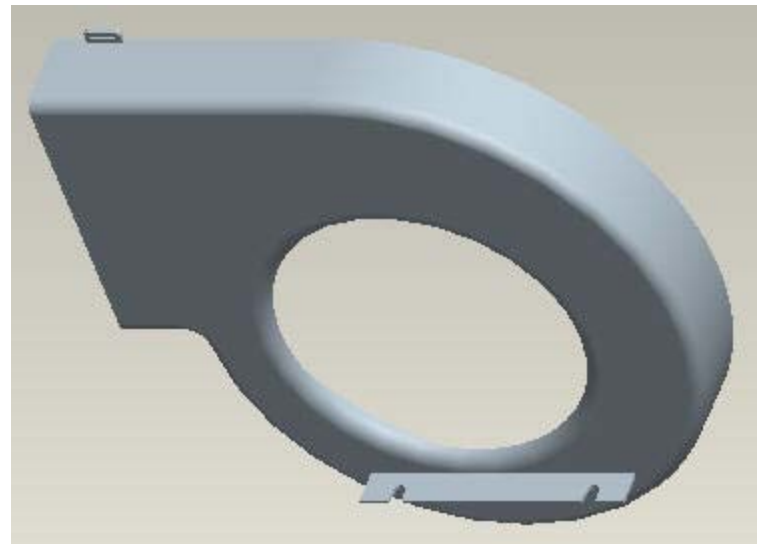

# SKELETONS AND MOTION

When starting a new design project, you should determine if you need motion simulation of design assembly. If you do need motion simulation of the design assemblies then you should plan right from the beginning and incorporate motion at the top level of product definition. This makes sure that finished product meets all the design criteria.

In this chapter we will learn how to incorporate motion at the top level of a product definition by following techniques

1. Standard Skeleton
2. Motion Skeleton

## EXERCISE 1

The topics covered are as follows.

- ❖ Creating a four bar mechanism by using the Standard Skeleton model
- ❖ Defining conceptual design of the mechanism using sketch features
- ❖ Creating Mechanism Constraints
- ❖ Simulating the mechanism

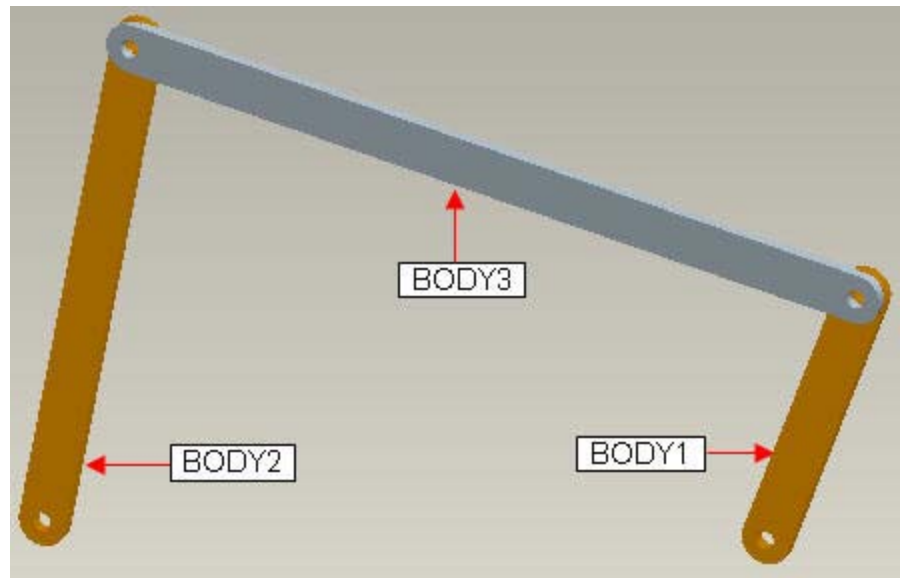

## EXERCISE 2

The topics covered are as follows.

- ❖ Creating a mechanism for a Pick-and-Place device
- ❖ Selecting stable references
- ❖ Simulating the mechanism

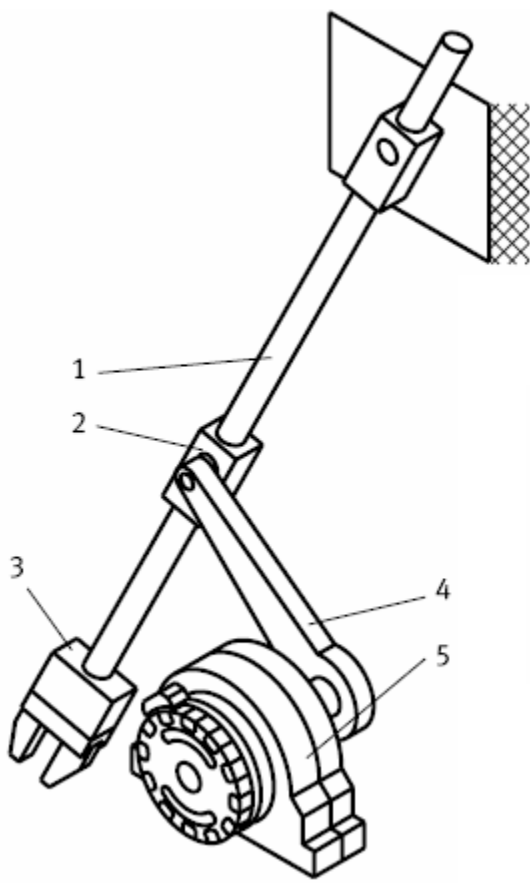

**Pick-and-place devices**

- 1** Guide rod
- 2** Rotary joint
- 3** Gripper
- 4** Swivel arm
- 5** Semi-rotary drive

A sample Pick-and-Place device  
Courtesy of Festo

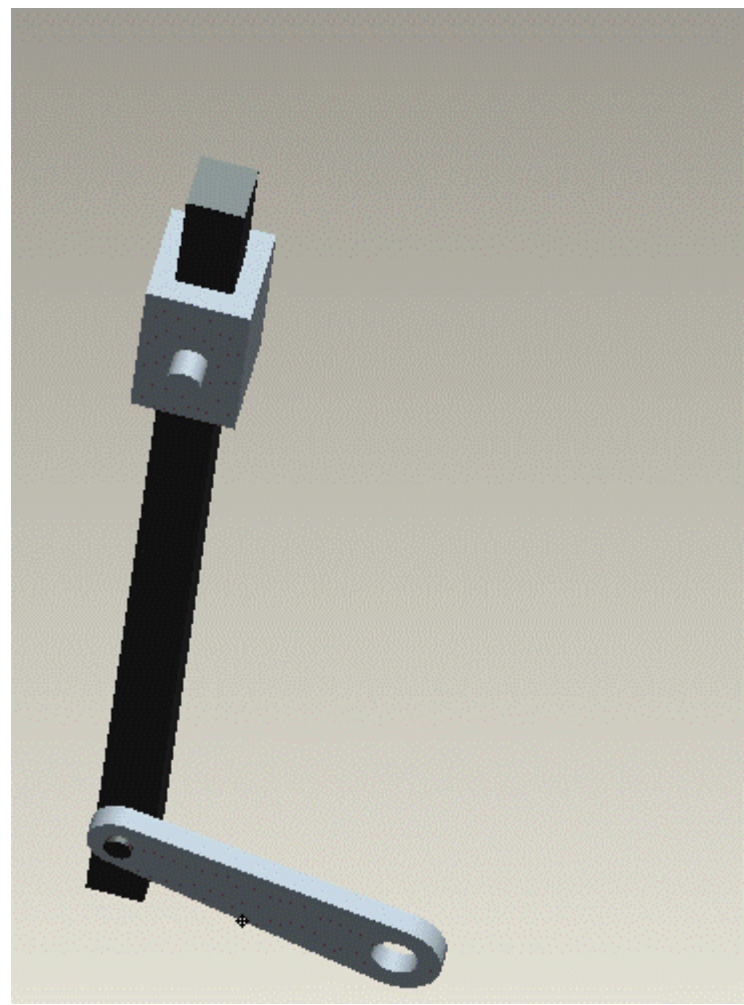

**EXERCISE 3**

The topics covered are as follows.

- ❖ How to simulate a mechanism in the sketcher
- ❖ Selecting stable references
- ❖ Simulating the mechanism

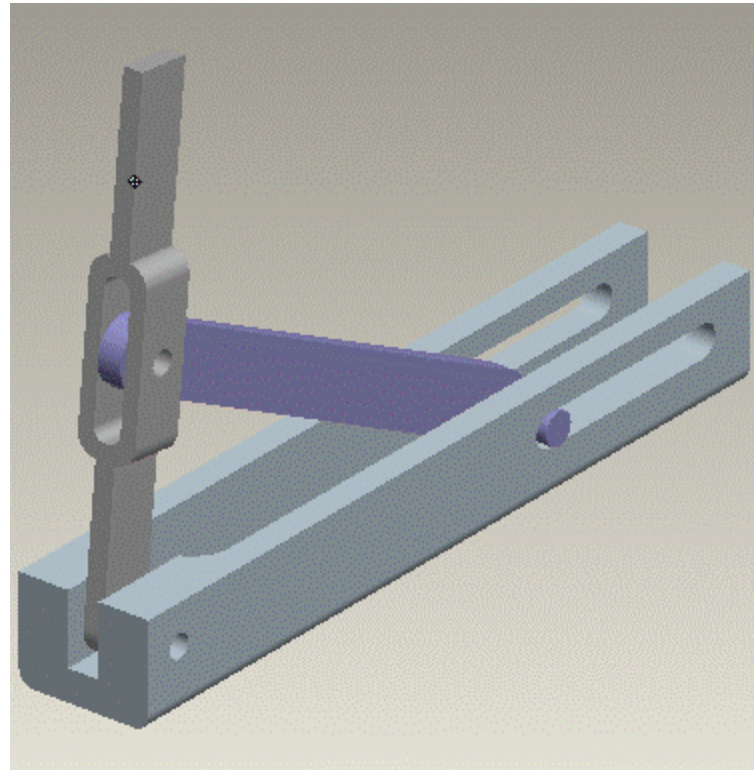

## EXERCISE 4

The topics covered are as follows.

- ❖ How to use the motion skeleton to incorporate motion at the top level of a design project
- ❖ Simulating the mechanism

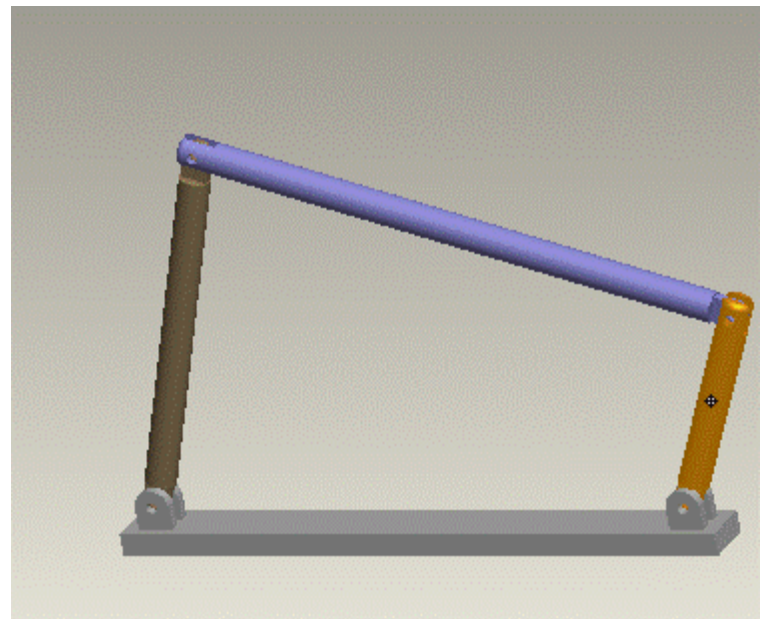

## FAMILY TABLE OF SKELETON

Skeleton models can maintain their own family tables. This means that assemblies can maintain different skeleton instances across a family table.

This is a great way to create the multiple configuration of an assembly driven by a skeleton.

## EXERCISE 1

The topics covered are as follows.

- ❖ How to use the family table of a skeleton model to create multiple configuration of a product.

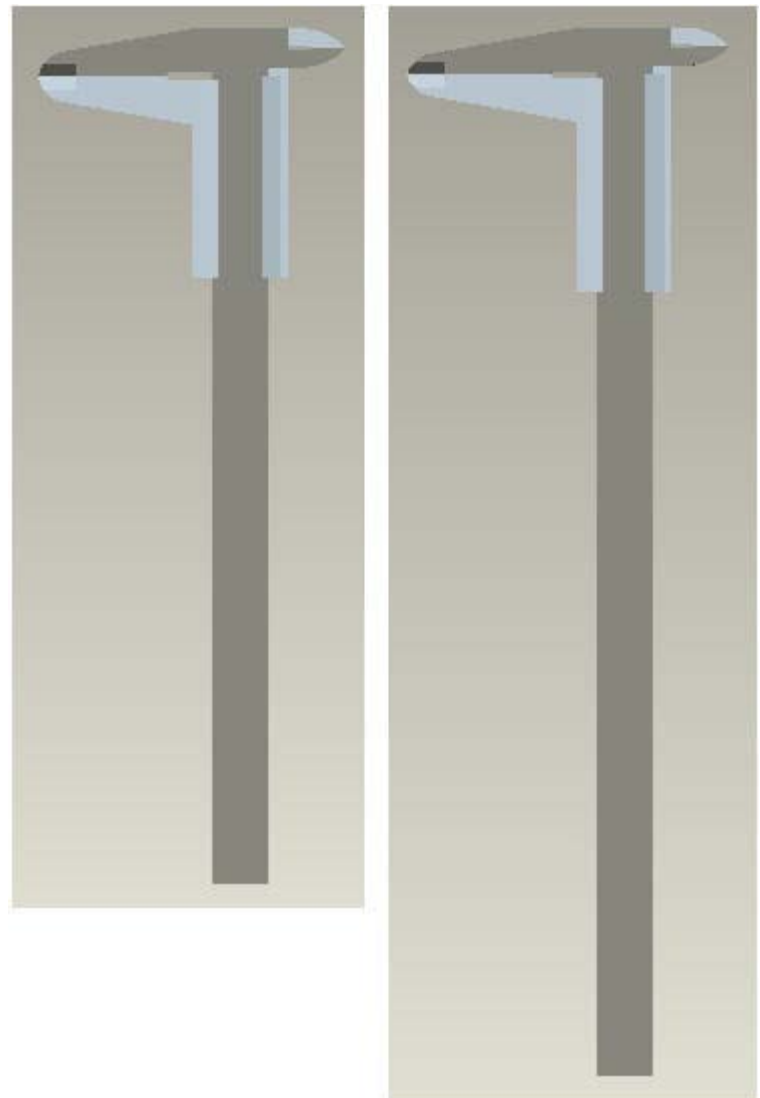

Two Configurations of a Product Assembly

# LAYOUTS

A Layout can be described as an engineering notebook where we can define parameters and relations related to a project. It maintains design intent in a central location.

Part and assembly models can both access these parameters and information in a layout.

## EXERCISE 1

The topics covered are as follows.

- ❖ How to create a layout
- ❖ How to create parameters in the layout by using Parameters dialog box
- ❖ How to declare a layout to the part models
- ❖ How to control dimensions in the parts by the parameters in the layout



## EXERCISE 2

The topics covered are as follows.

- ❖ How to import a 2D sketch in the layout
- ❖ How to create parameters in the layout by defining global dimensions

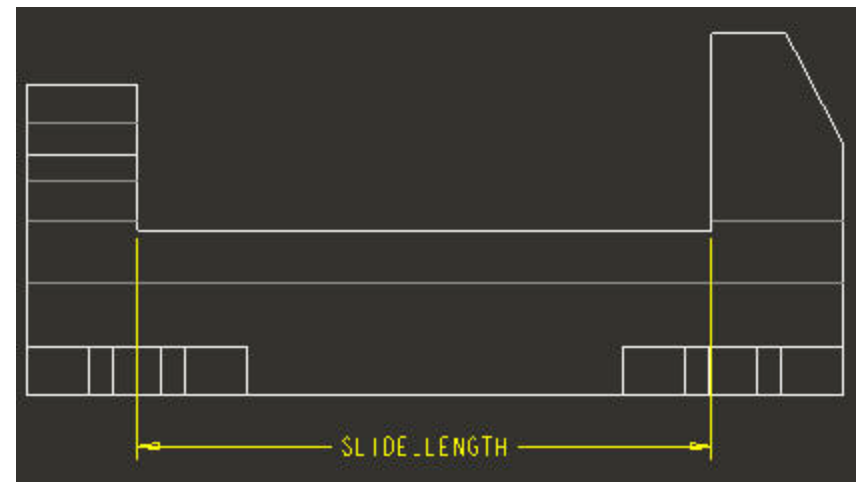

## EXERCISE 3

The topics covered are as follows.

- ❖ How to implement the Top-Down design to an existing assembly that was created using Bottom-Up approach
- ❖ How to control location of components in the assembly by the parameters in the layout.
- ❖ Using the standard skeleton as Placement Skeleton

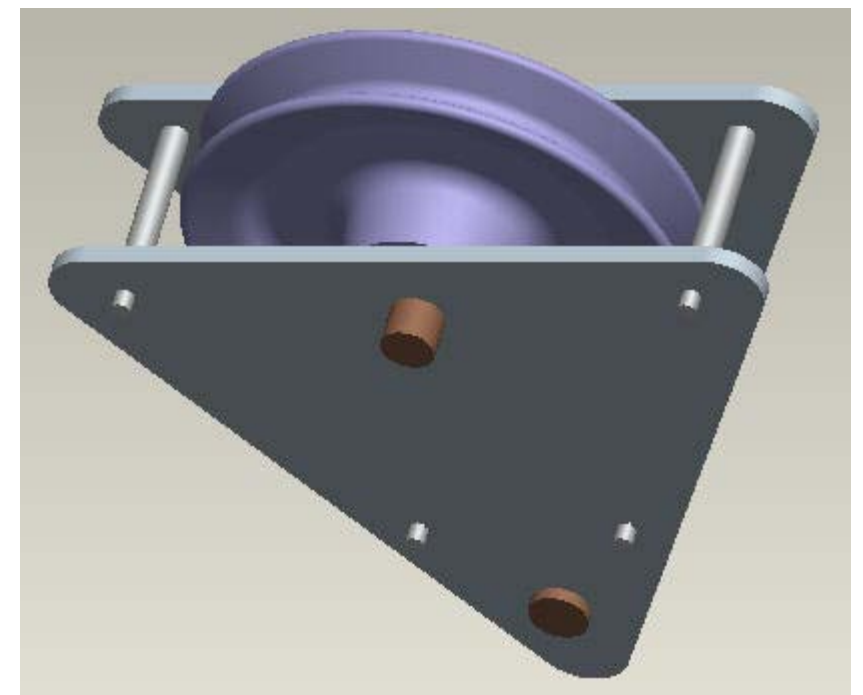

## DERIVATIVE MODELS

There may be situations when we may want to create a CAD model that is based on or has some relation to an existing model. For example we may want to create a new part for flat state of a sheet metal part or create a mirror copy of an existing part. For such derivative models Pro/E provides a number of tools. In this chapter we will discuss the following tools available

1. Merge Feature
2. Inheritance Feature
3. Shrinkwrap Feature
4. Mirror Functionality

### EXERCISE 1

The topics covered are as follows.

- ❖ Creating a single component that represents the weldment of several components by using the Merge feature.
- ❖ Investigating the external references created by a Merge feature

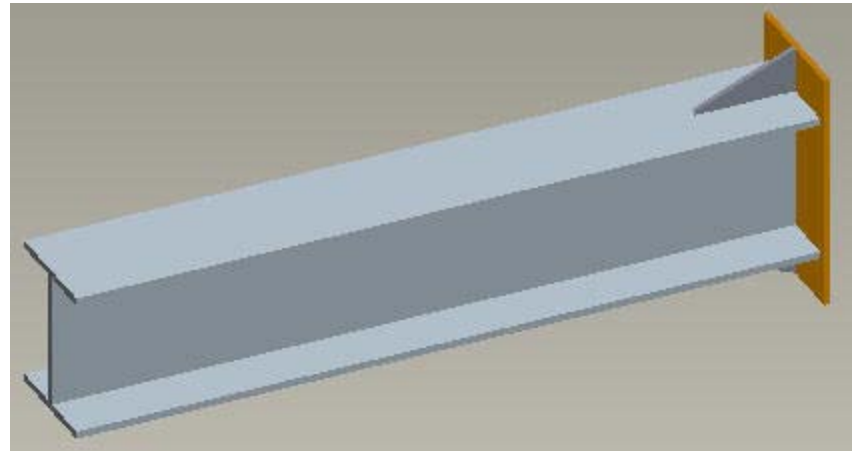

Assembly of Components

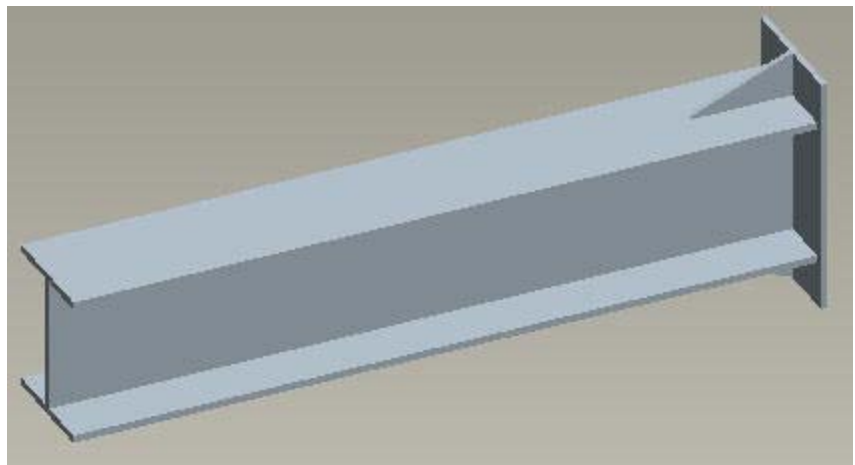

Weldment

## EXERCISE 2

The topics covered are as follows.

- ❖ Creating a single component that represents the weldment of several components by using the External Merge feature.
- ❖ Investigating the external references created by an External Merge feature

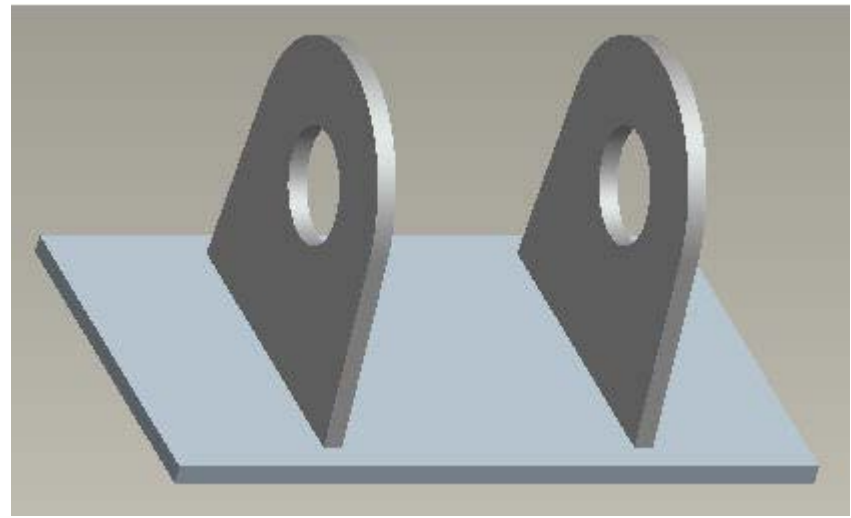

Assembly of Components

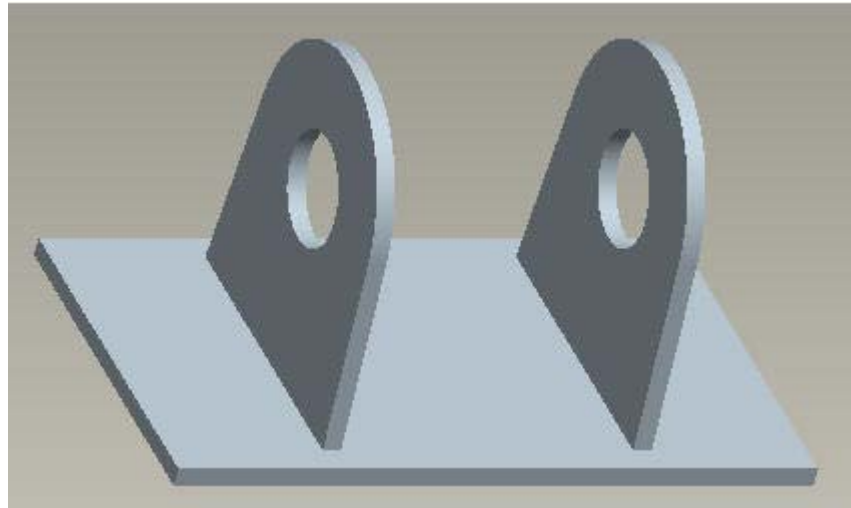

Weldment

## EXERCISE 3

The topics covered are as follows.

- ❖ Creating an Inheritance model and suppressing the unwanted features.
- ❖ Creating a casting model for a part that will require machining operations later.

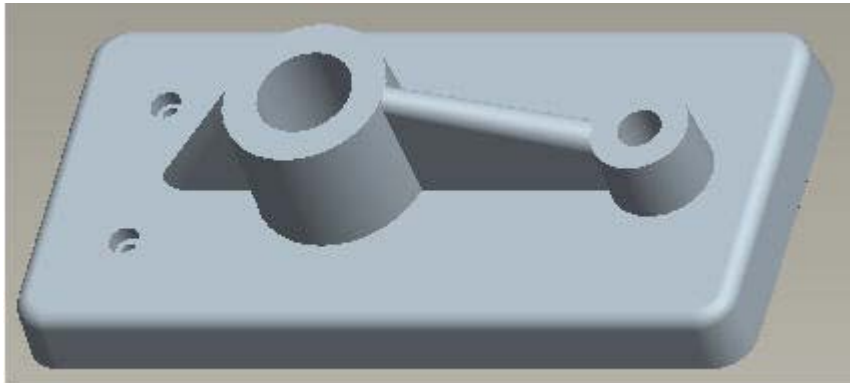

Finished Part

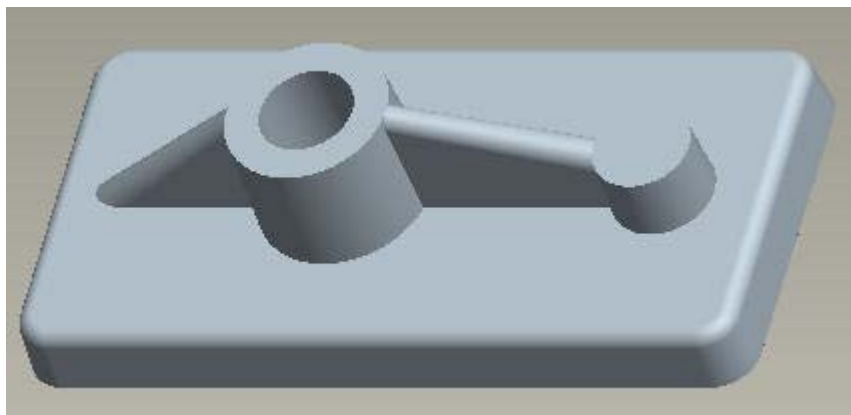

Casting Model



## EXERCISE 4

The topics covered are as follows.

- ❖ How to change the dimensions of features in an Inheritance model.
- ❖ Suppressing unwanted features in Inheritance part
- ❖ Adding features in Inheritance Part

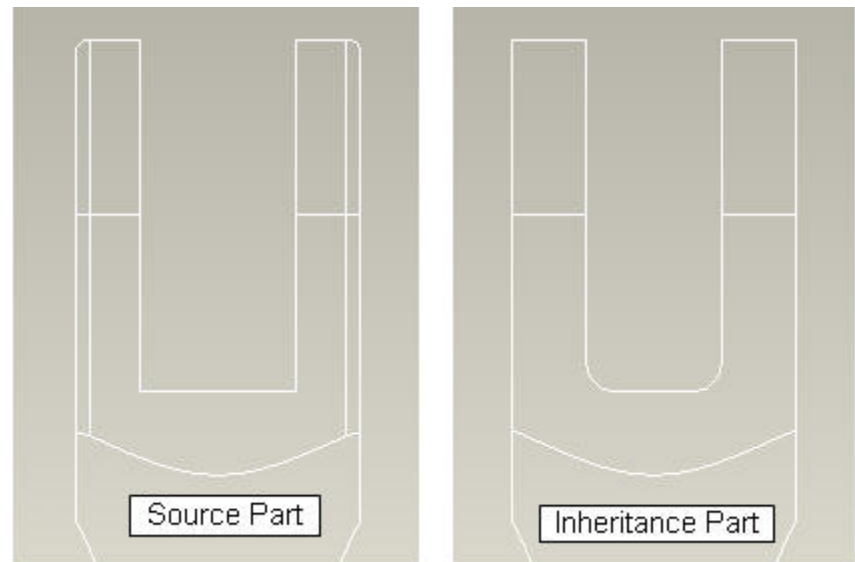
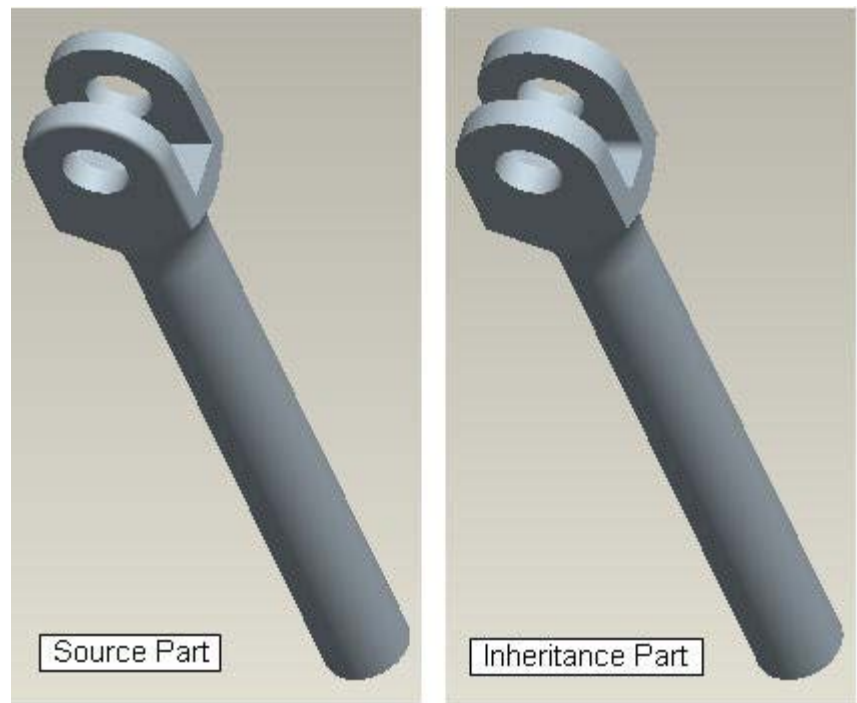

## EXERCISE 5

The topics covered are as follows.

- ❖ How to create a flat state part of a sheet metal part by using the Inheritance feature.

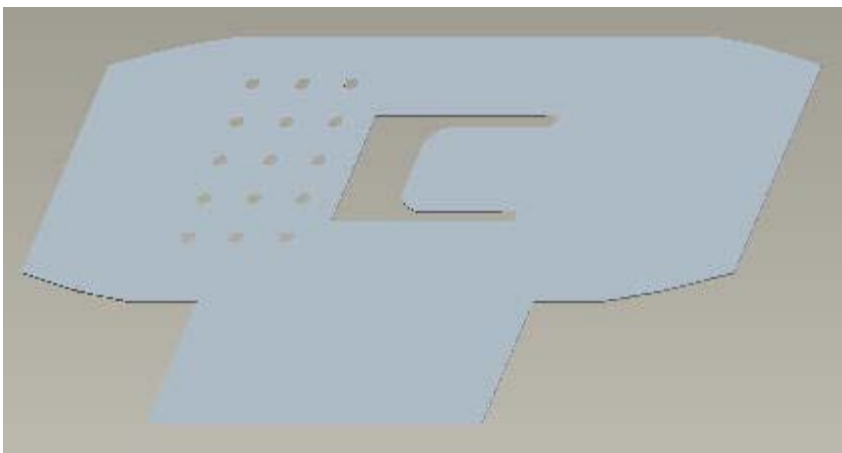

Flat State Part

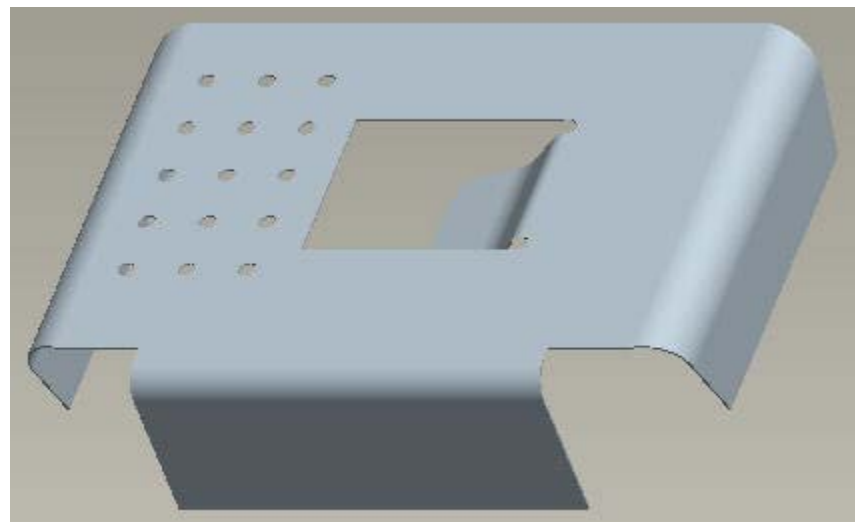

Sheet Metal Part

## EXERCISE 6

The topics covered are as follows.

- ❖ How to create a mirrored part

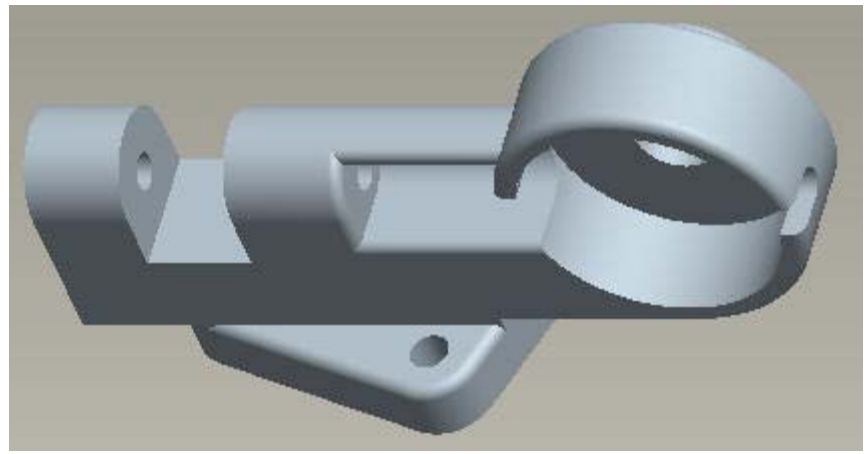

Source Part

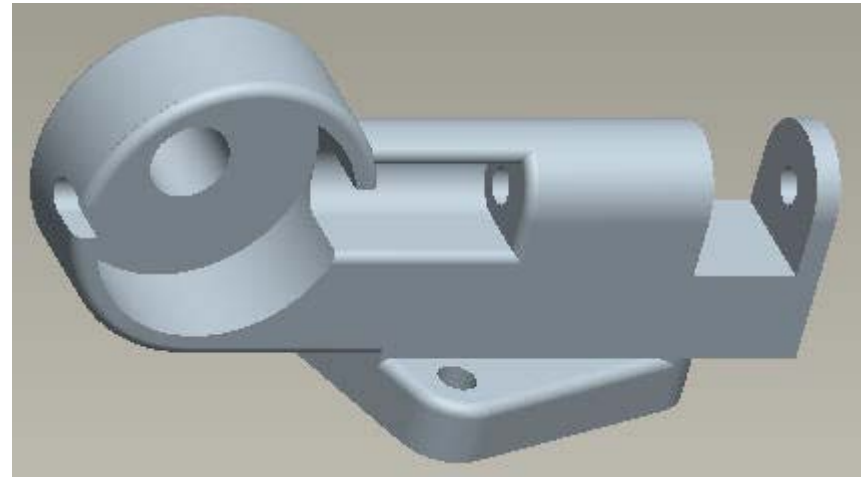

Mirrored Part

## EXERCISE 7

The topics covered are as follows.

- ❖ How to create a mirrored part when it is slightly different from the source part.



Source Part



Mirrored Part

## CONCLUSION

In this chapter we will discuss in a nutshell what top-down tools and techniques should be used in what scenarios.