

Pro/NC

Pro/NC tutorials have been developed with great emphasis on the practical application of the software to solve real world problems. The self-study course starts from the very basic concepts and teaches advanced techniques step by step. After completing these tutorials an Engineer or CAM Programmer will be able to easily machine any CAD model on a three axis milling machine, generate required downstream documentation for job setting, create NC templates and configure Post-Processor for a given CNC controller.

The training material is divided into sections. Each section is accompanied with exercises to practice the concepts learned.

1. [Introduction](#)
2. [Face Milling](#)
3. [Volume and Local Milling](#)
4. [Roughing and Reroughing](#)
5. [Plunge Milling](#)
6. [Profile Milling](#)
7. [Surface Milling](#)
8. [Finishing](#)
9. [Trajectory Milling](#)
10. [Engraving](#)
11. [Hole Making](#)
12. [Thread Milling](#)
13. [Tool Manager](#)
14. [Process Manager](#)
15. [Manufacturing Process Information](#)
16. [Manufacturing Template](#)
17. [Post Processing](#)

Prerequisites

The user should have basic concepts in the following

- 1) Solid Modeling
- 2) Surface Modeling
- 3) Assembly

Stats

Following are the stats for WF 5.0

Total Pages: **622**

Total Exercises: **85**

INTRODUCTION

This tutorial will introduce to the basic steps of setting up a manufacturing model in Pro/NC.

The topics covered are as follows.

- Creating a new manufacturing model
- Assembling the reference model
- Creating the workpiece
- Defining the style state for workpiece
- Defining the operation and workcell
- Creating new tools
- Concept of Accuracy in Pro/E

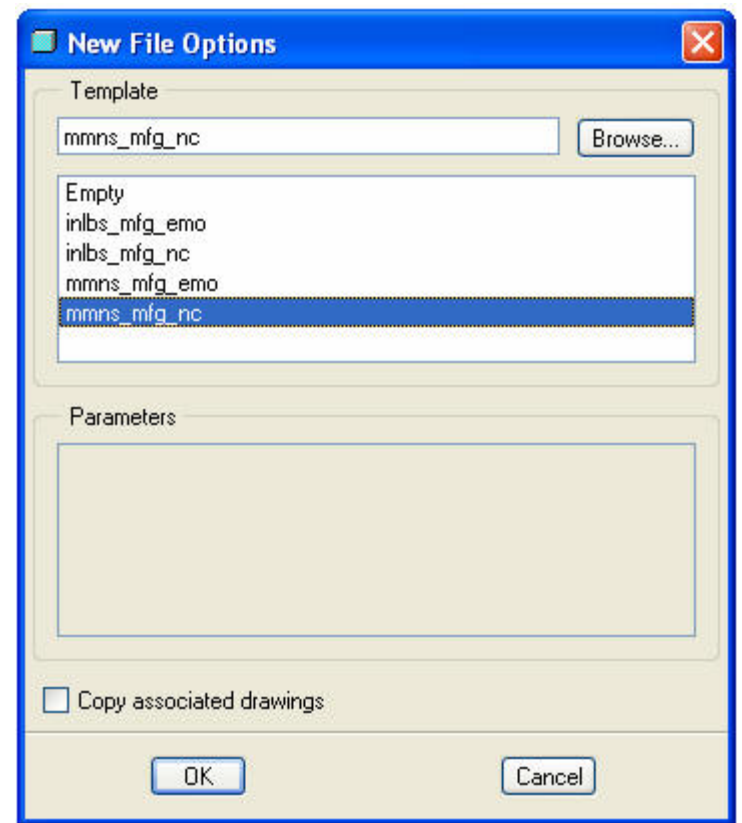

Specifying the template file

FACE MILLING

Face milling NC Sequence is used to face down the workpiece. Usually it is the first sequence in machining a part.

The topics covered are as follows.

- Defining a new face milling NC Sequence
- Defining relations for cutting parameters
- Optimizing the toolpath for longer tool life
- Set the toolpath to cut the material using climb milling strategy
- Avoiding direct plunge motion into the material
- Changing the start point
- How to perform multi step machining

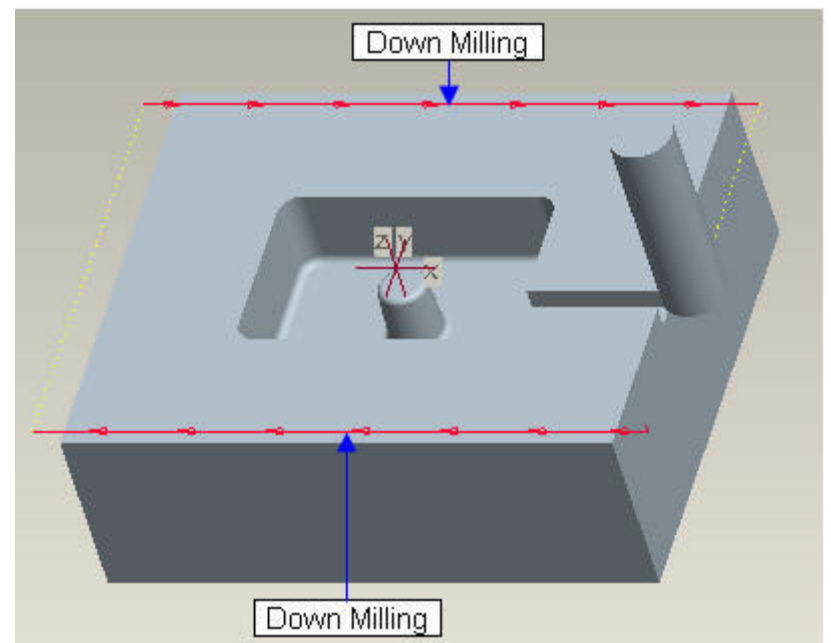

Facing a Part

VOLUME AND LOCAL MILLING

Volume milling NC Sequence is a 2.5 axis sequence. It is a very versatile sequence used not only to rough machine the workpiece but can also perform finishing and facing operations.

It is the mostly used NC Sequence while machining a part. So it is given its due share in our tutorials.

- Defining a new Volume milling NC Sequence
- Controlling the cutting condition at corners to avoid vibration
- Specifying the linear ramp motion instead of plunge
- Specifying the helical ramp motion
- Controlling the cutting feed along ramp motion
- Simulating toolpath in Vericut for verification
- Specifying an axis for plunge motion to the next slice
- Defining a Local Milling NC Sequence for rest milling operation
- Using Volume Milling for profiling of the walls of the mill volume
- Controlling the entry/exit condition of the tool
- Controlling the surface finish by specifying scallop or cusp height
- Performing profiling and facing within a single NC Sequence by using pocketing strategy of Volume Milling
- Customization of the toolpath
- How to copy a NC Sequence and specify new references
- How to use excluded surfaces option to exclude the selected surfaces from profiling
- How to control the entry/exit into cut for longer tool life and less machine tool acceleration/deceleration
- Introduction to the following entry/exit movements between slices
 1. Lea in, Lead out
 2. Ramping
 3. S-shape Connections
- Defining a local milling NC Sequence to machine the material left at corners by a previous tool

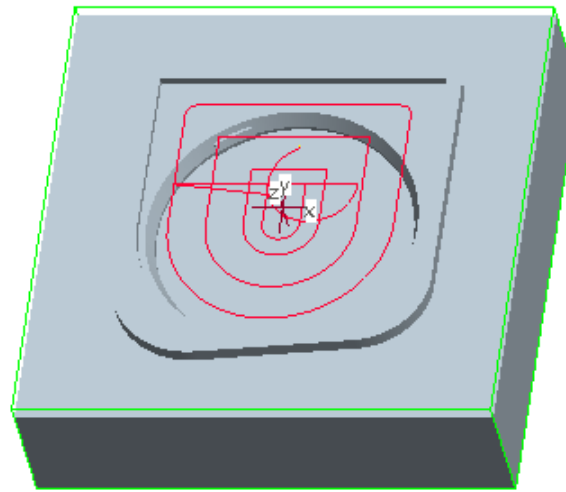

Roughing a Cavity- Helical Entry and Minimum Corner Radius Control to Avoid Vibration at Corner

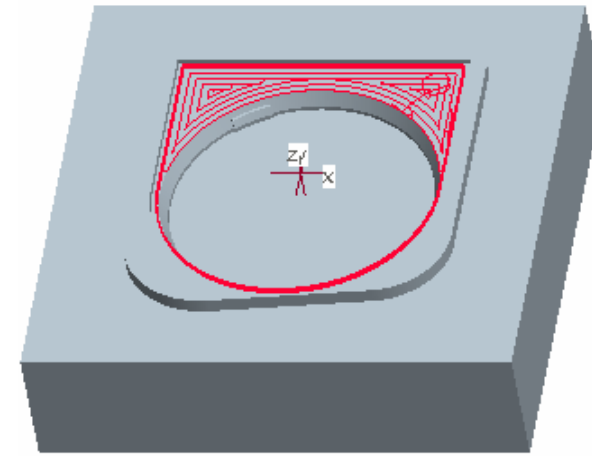

Pocketing- Profiling of Walls and Facing of Horizontal Surfaces within a single NC Sequence

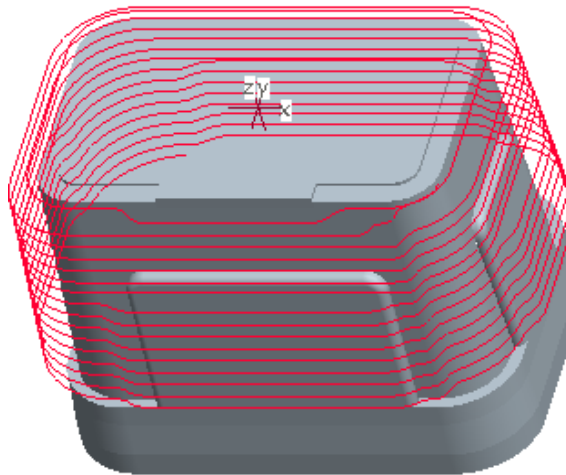

Profiling- Finishing of Steep Walls with "S" Connection, Tool Stays in Constant Contact

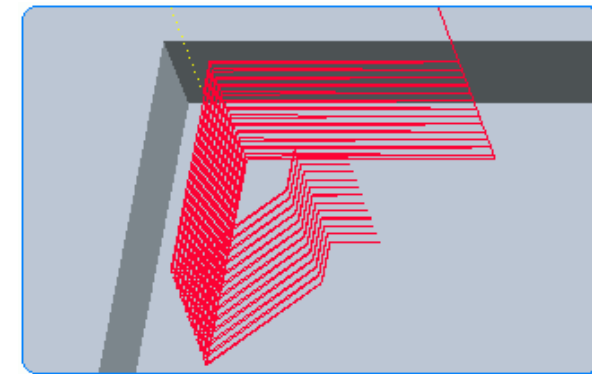

Local Milling- Machining the material left by previous tool

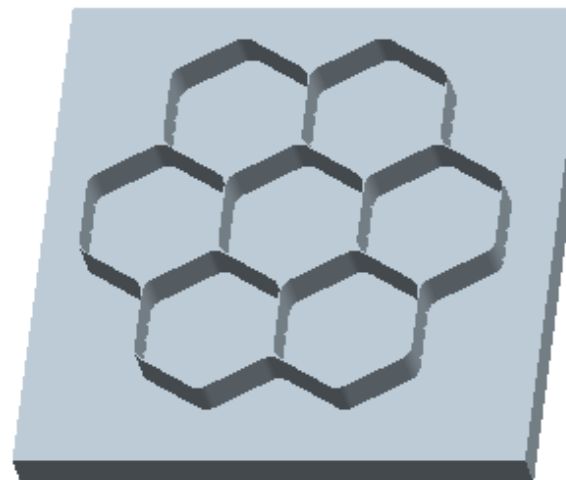

Thin Wall Structure

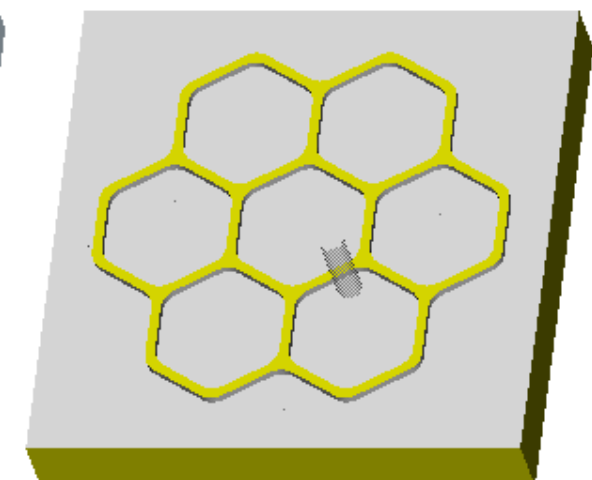

Machining of Thin wall component with Slice by Slice Scanning

- Facing a part's top surface
- Defining a Mill Window
- Specifying Tool Side for Mill Window
- Machining with Slice by Slice strategy
- Declaring Approach Walls for a Mill Volume
- Offsetting the selected surface of a Mill Volume
- Introduction to Smart retract option
- Introduction to Top Surfaces functionality

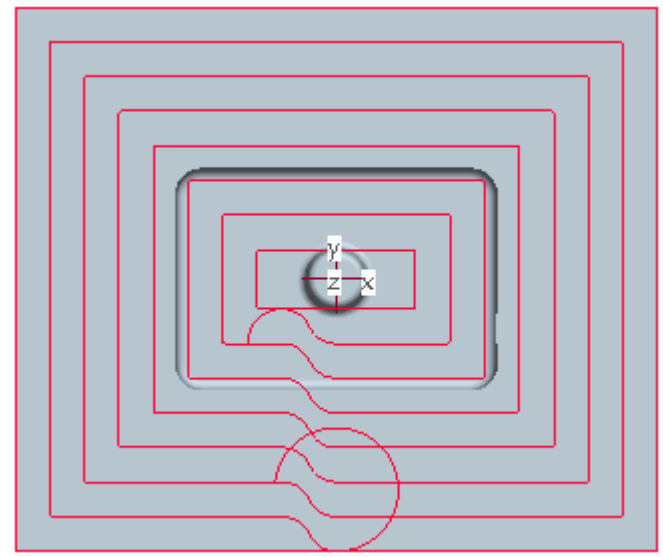

High Speed Facing- Single Entry/Exit, "S" Connection between Passes, Corner Rounding

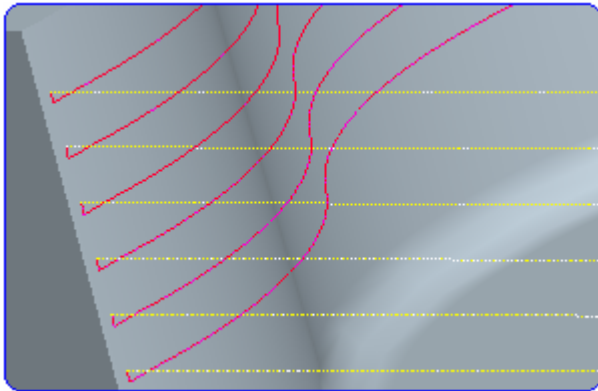

Smart Retract- Minimizes the time wasted in Retract and Plunge movements

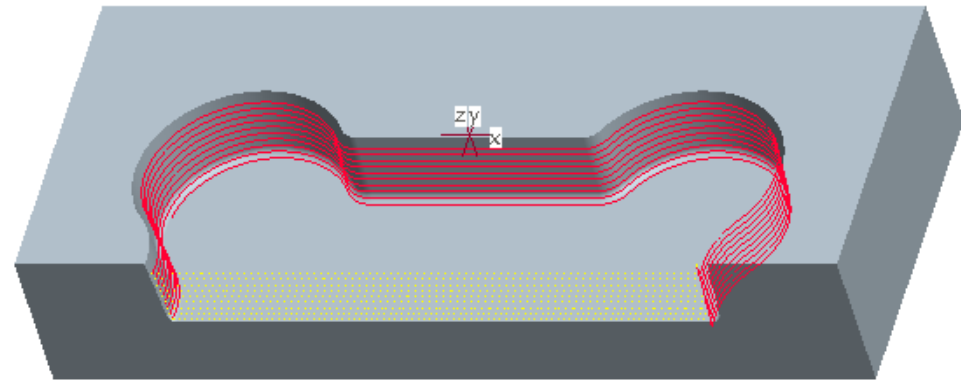

Exclude Surface and Smart Retract to optimize the Finishing

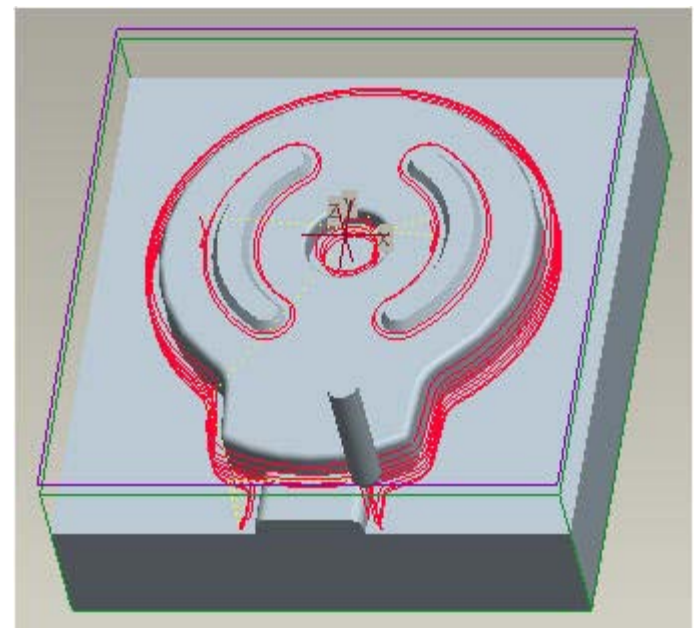

Mill Window requires less references to select

ROUGHING AND REROUGHING

Roughing and Reroughing NC Sequence are used specifically for high-speed mold machining. They allow different scanning strategies within single sequence.

The topics covered are as follows.

- Defining a new Roughing NC Sequence
- Creating a Mill Window within and outside the NC Sequence and specifying its Depth
- Choosing the most suitable toolpath scanning strategy
- Optimizing the toolpath for high speed machining
- Eliminating the sudden direction changes with the smooth transition moves
- Scallop Height control
- Implementing different scanning strategies within single sequence
- Defining a new Reroughing NC Sequence
- Simulation of two sequences in the Vericut simultaneously
- How to confine the re-roughing to a desired region

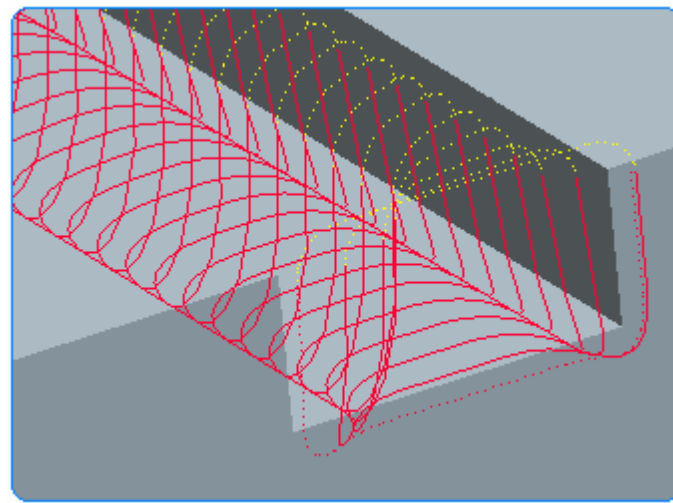

Trochoidal Milling of Slots-No Sudden Direction Change, Constant Tool Engagement

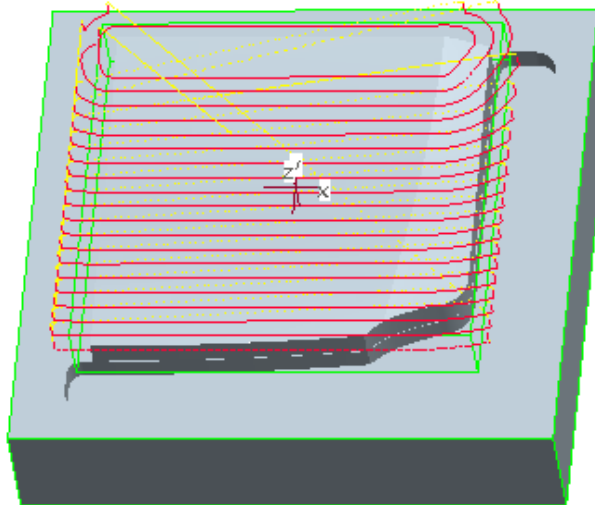

Intelligent Recognition of Stock to avoid Air Cuts

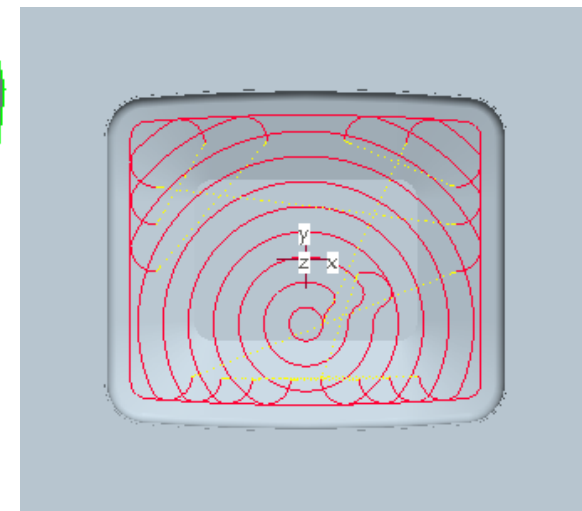

High Speed Roughing-Smooth "S" Connection, Tangent Entry/Exit with Minimum Radius Control

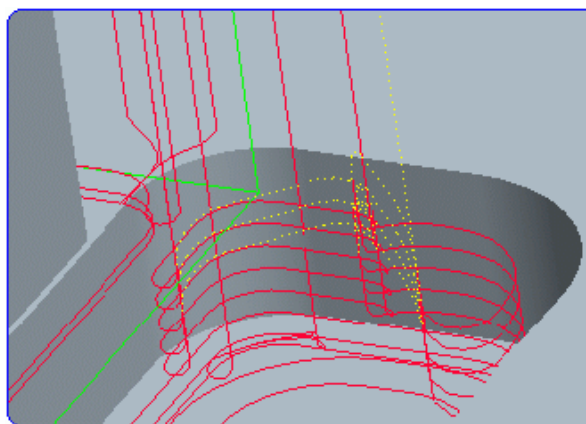

Reroughing: Accurate Computation of Leftover Material

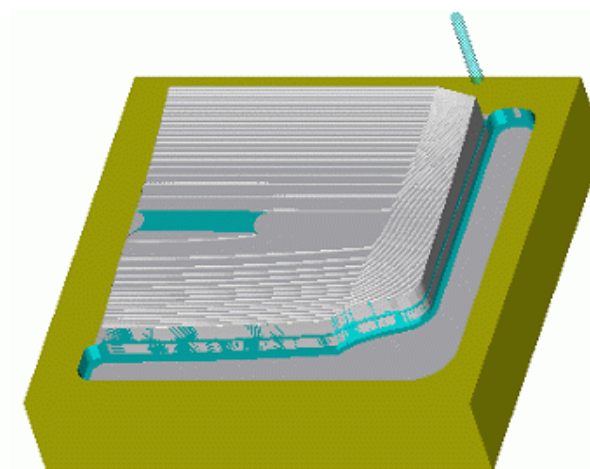

Simulation in Vericut of Roughing and Reroughing Sequences

PLUNGE MILLING

Plunge milling is used to rough machine a workpiece by a series of overlapping plunges into the material.

The topics covered are as follows.

- Defining a new Plunge Milling NC Sequence
- Creating a Mill Window
- Creating a new plunge milling cutter

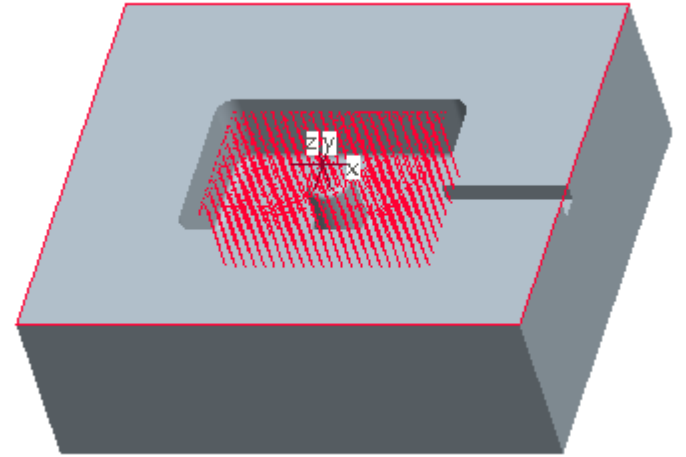

Plunge Milling to Rough out a Cavity

PROFILE MILLING

Profile milling NC Sequence is a 2.5 axis sequence. It is usually used to semifinish or finish the vertical or slanted surfaces.

The topics covered are as follows

- Defining a Mill Surface as “Machinable Area”
- Defining a new Profile Milling NC Sequence
- Creating smooth entry/exit motions
- Setting up Retract plane at NC Sequence level to reduce non-cutting time of tool
- Machining a sharp corner with a single pass of cutter
- Controlling the plunge movement of the tool at the center of a hole
- Machining the selected surfaces with multiple passes with a single NC Sequence.
- How to get the manufacturing information for a sequence
- Creating CL data for a given NC Sequence
- How to mirror the CL Data
- Machining an undercut
- Defining a side milling cutter
- Selection of surfaces by loop option
- Checking visually, by placing the tool at desired location, to see if any gouges occur
- Defining a new profile milling NC Sequence to machine and undercut
- Introduction to NORMAL_LEAD_STEP parameter
- Inserting a CL Command at the end of CL Data
- Patterning a NC Sequence
- Generating CL Data for a patterned NC Sequence
- Gouge checking patterned NC Sequence
- Defining a Sloped mill surface
- Introduction to Check Surfaces functionality
- Setting the “option file” option related to check surfaces.

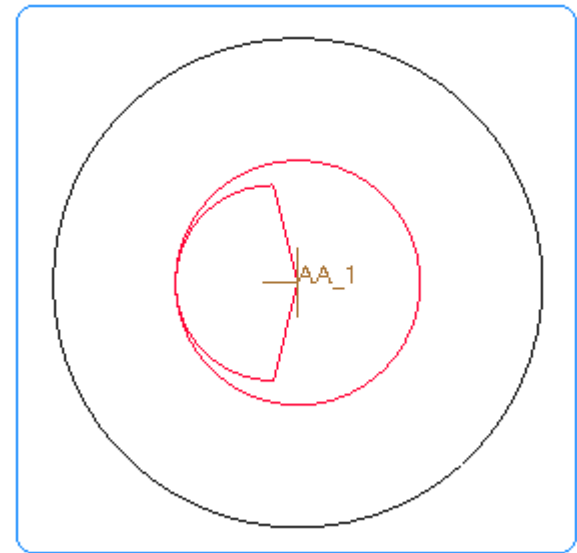

Finishing of Holes-Plunging at Centre Axis

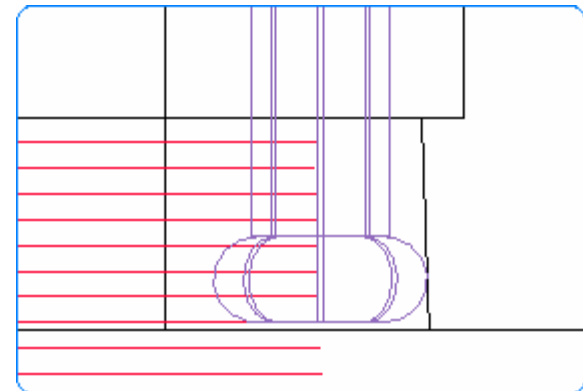

Machining of Undercut with Side Milling Cutter

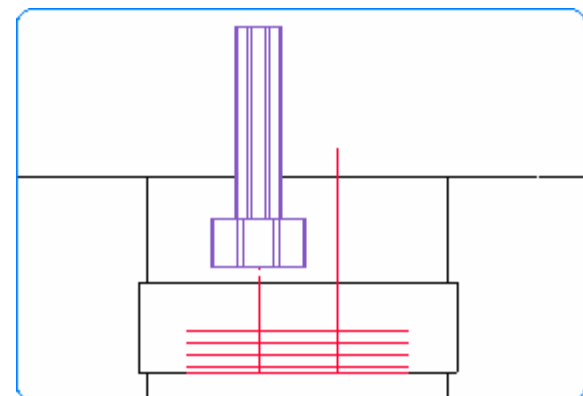

Machining of Groove with T-Slot Cutter

SURFACE MILLING

Surface milling NC Sequence is usually used to semi-finish or finish the shallow surfaces. It is a versatile sequence which can generate a lot of toolpath strategies.

The topics covered are as follows

- Defining a new surface milling NC Sequence
- Introduction to different cut definition options to suit the surface topology
- Choosing the proper scanning strategy
- Controlling the connection movement between cutting passes
- Introduction to available entry/exit movements
- Creating multi-step toolpaths
- Defining Sloped Mill Surface to classify surfaces based upon slope angle
- Defining surface milling NC Sequence to finish a hole
- Controlling the cutting direction
- Selecting suitable SCAN_TYPE for selected surfaces
- Introduction to ARC_TANGENT entry/exit condition
- How to create CL data for a given NC Sequence
- How to mirror the CL Data
- Adding Auto Inner Cutlines
- Adding smooth Entry/Exit motions
- Adding smooth connection movements between tool passes
- Inserting a CL Command at the end of CL Data
- Patterning a NC Sequence
- Generating CL Data for a patterned NC Sequence
- Gouge checking patterned NC Sequence

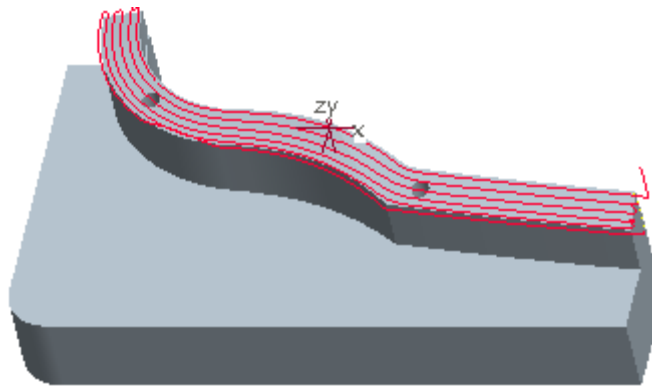

Cutline Machining follows surface topology

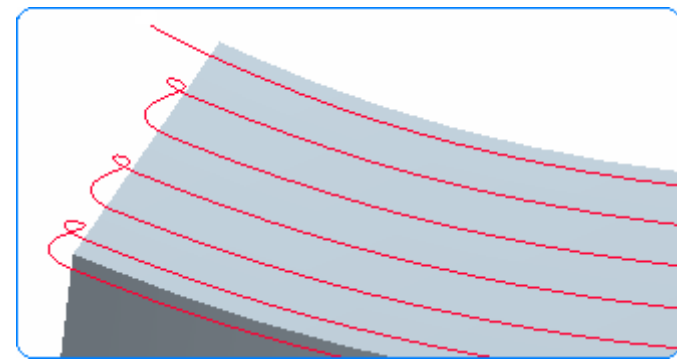

Smooth Connection Movement for HSM

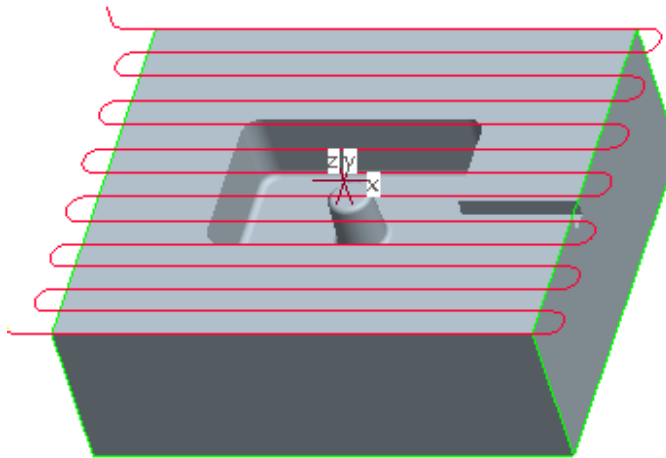

High Speed Facing

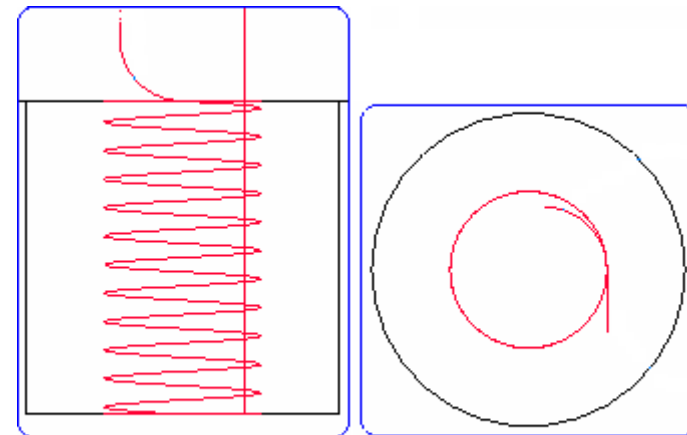

Finishing of Holes using Helical Scanning

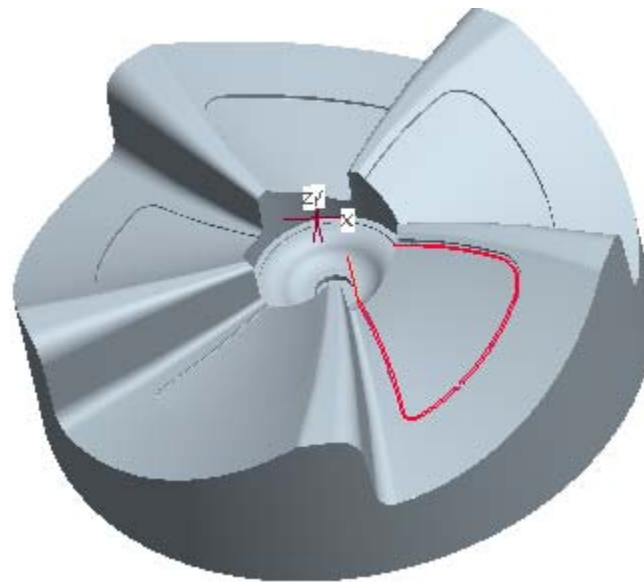

Using the Surface Sequence to machine the material left by previous tool.

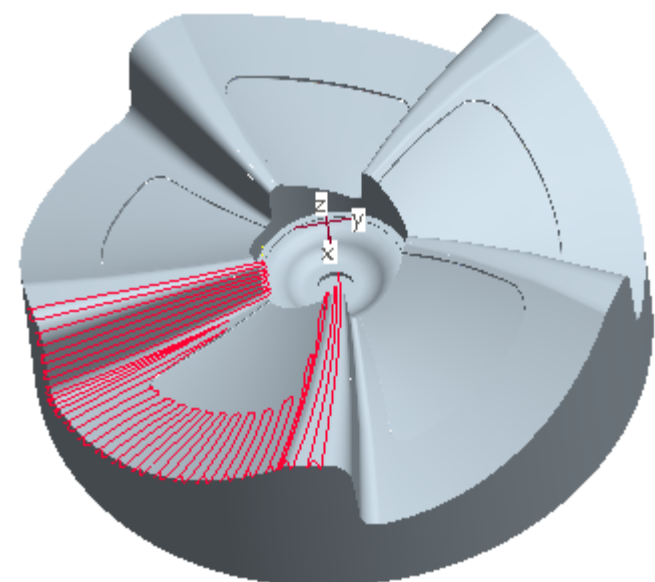

Using the Surface Edges to Smoothen the Toolpath

FINISHING

Finishing is a new NC Sequence that first analyses and then applies suitable machining strategy according to the geometry of reference model.

The topics covered in this tutorial are as follows

- Defining a new Finishing NC Sequence
- Creating a Mill Window
- Profiling of steep surfaces
- Optimizing the entry/exit into slice
- Machining the shallow surfaces of reference model
- Machining only the flat surfaces of reference model
- Excluding surfaces from toolpath computation
- Defining Close Loops for the part
- Specifying Tool Side for Mill Window
- Specifying Offset for Mill Window
- Machining the complete part using the Spiral scan

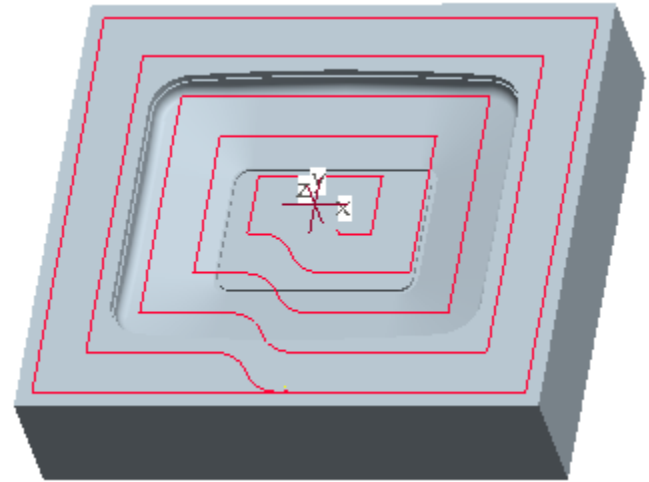

Facing by defining Close Loops

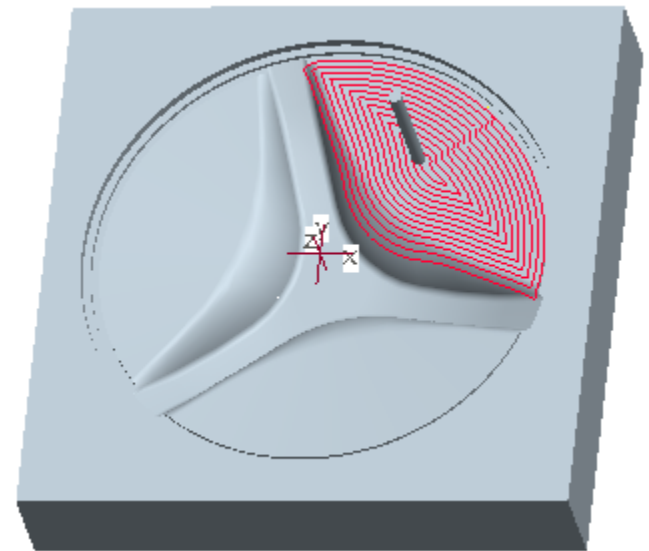

Finishing both the steep and shallow surfaces

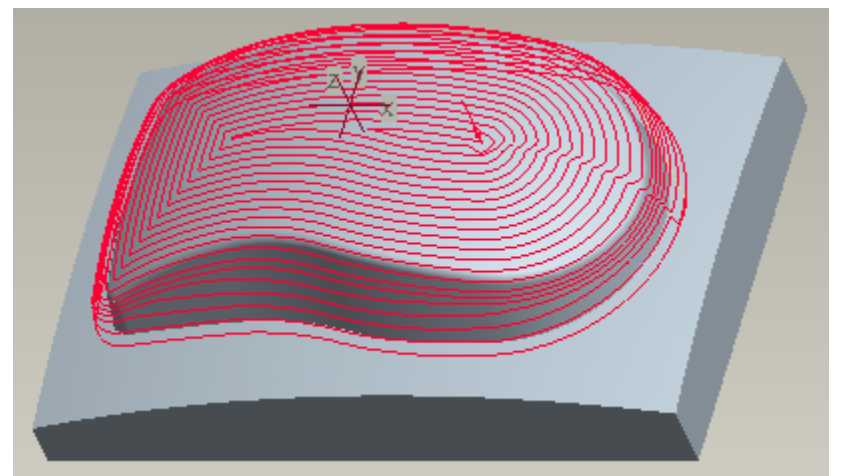

Machining the complete part using the Spiral scan

TRAJECTORY MILLING

Trajectory milling is a 3 to 5 axis milling sequence. It allows to sweep a tool along any user-defined trajectory. It gives the user very low level control over the tool path.

The topics covered are as follows.

- Defining a Composite datum curve
- Defining a 2-Axis trajectory milling NC Sequence.
- How to perform 2-Axis multi-step trajectory milling
- How to perform 2-Axis multi-pass trajectory milling
- Defining a 3-Axis trajectory milling NC Sequence.
- Adding smooth entry/exit motions.
- Checking the gouges against reference part.
- Shifting the toolpath upward to avoid gouging by using `AXIS_SHIFT` parameter
- How to perform 3-Axis multi-step trajectory milling.
- Machine a slot in multiple steps
- Controlling the connection movement between slices by `CONNECTION_TYPE` parameter
- Machining a slot (groove) which lies on a curved surface
- Face a part by a succession of trajectory passes

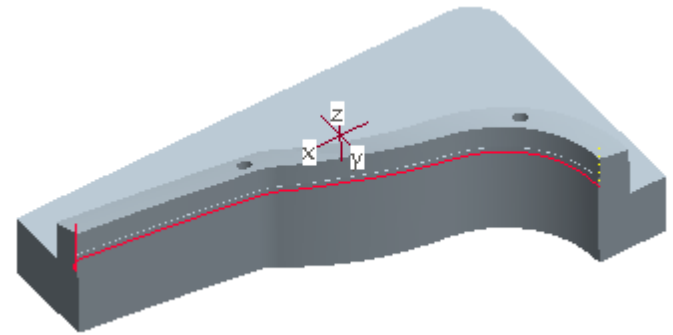

Driving the Tool along 3D Trajectory

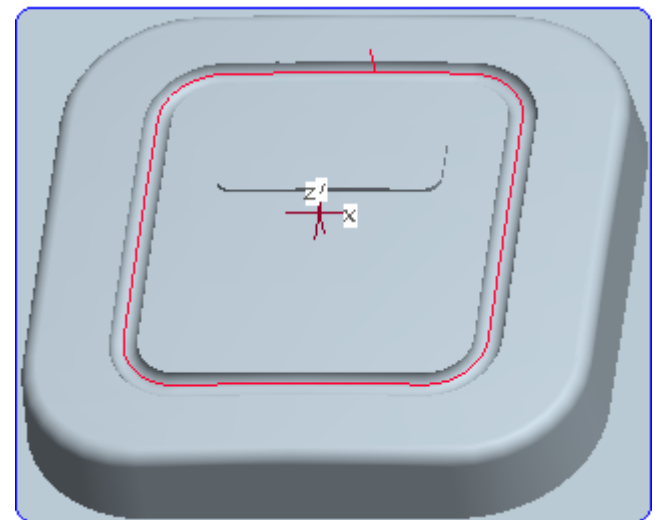

Machining of 3D Grooves

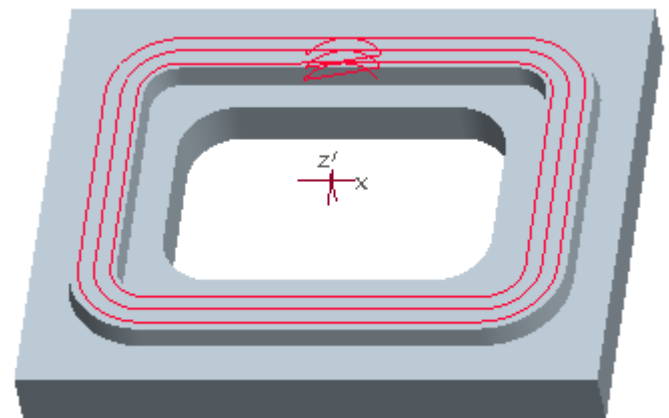

Customized Facing to Reduce Non-Cutting Time

ENGRAVING

Engraving NC sequences are created to machine a Groove cosmetic feature

The topics covered are as follows.

- Creating a new Engraving NC Sequence
- Defining a new Grooving Tool
- Machining the Groove feature with multiple cuts



HOLEMAKING

A large number of operations like drilling, boring, countersinking, tapping and reaming can be performed by using proper Holemaking NC Sequence.

The topics covered are as follows.

- Introduction to different types of hole making sequences
- Standard Holemaking NC Sequence
- Countersink Holemaking NC Sequence
- Center-drilling the holes to the required depth
- Selection of holes for hole making sequence by following methods
 1. Axes
 2. Surfaces
 3. Diameters
 4. Parameters
- Creating Hole Sets to specify different depth options within a single sequence
- Specification of depth to which tool can travel by different methods
- Specification of tool retract height during traversing movement
- Drilling of hole by using peck drilling and high-speed peck drilling techniques

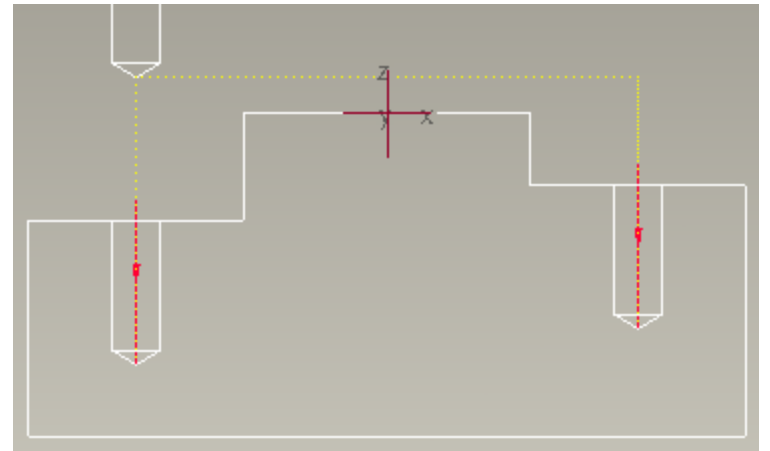

Automatic Determination of Drill depth

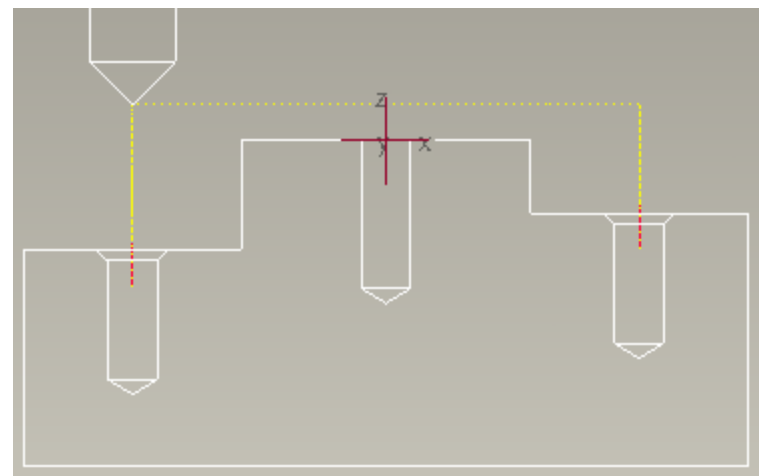

Countersinking

THREAD MILLING

Thread Milling NC Sequence is used to cut internal and external threads on cylindrical surfaces.

- The topics covered are as follows.
- Defining a Single-Tooth thread mill cutter
- Defining a Multi-Tooth Thread Mill cutter
- Defining a new Thread Milling NC Sequence
- Creating smooth entry/exit motions
- Creating Single Pass toolpath for multi-teeth cutters
- Creating Interrupted Motion toolpaths

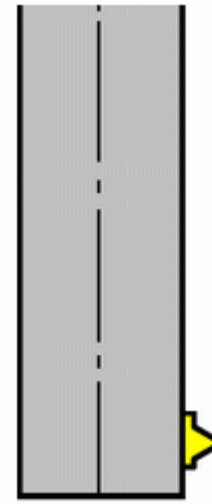

Single-Tooth Tool

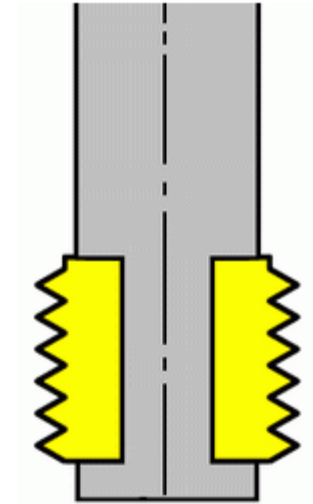

Multi-Tooth Thread Mill

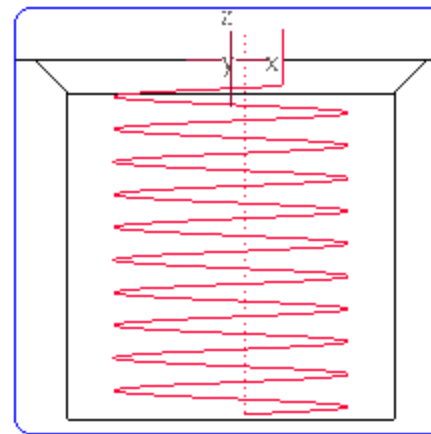

Front View

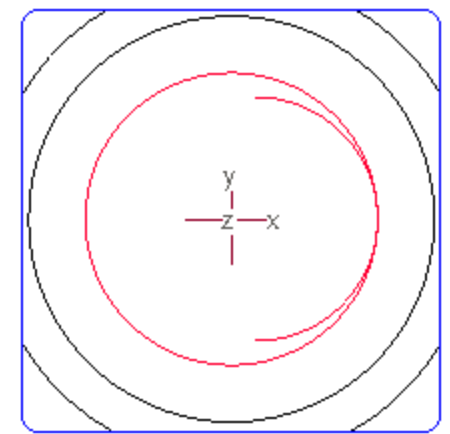

Top View

Machining Thread using Single-Teeth Tool

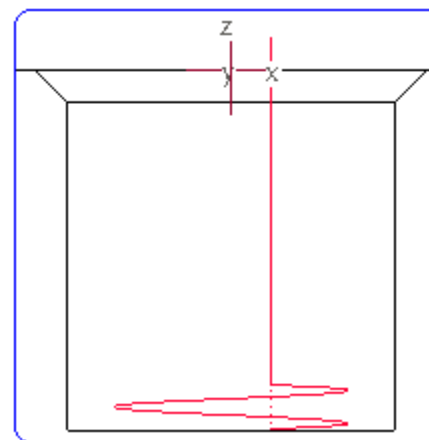

Single Pass Toolpath

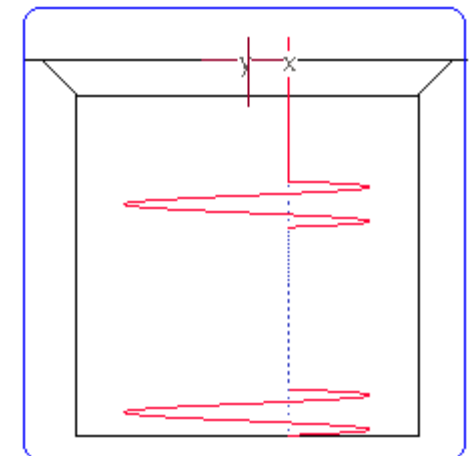

Interrupted Motion-Multiple Passes

Tool Manager

Tool Manager is used to define cutting tools. In addition to the geometry parameters you can also specify cutting parameters for a tool in the Tool Manager Dialog box

The detail of topics covered in this chapter is as follows.

- Defining a new Flat End Mill
- Defining a Ball End Mill with Holder
- Defining a Bull Mill with Holder
- Defining a Sketched tool.
- Defining a Solid tool.
- Adding non-geometry parameters to the Solid tool
- How to take the advantage of Holder in a Trajectory Milling NC Sequence
- Advantage of Solid tools over the Standard tools
- Copying NC parameters from the tool into a NC Sequence non-associatively
- Copying NC parameters from the tool into a NC Sequence associatively

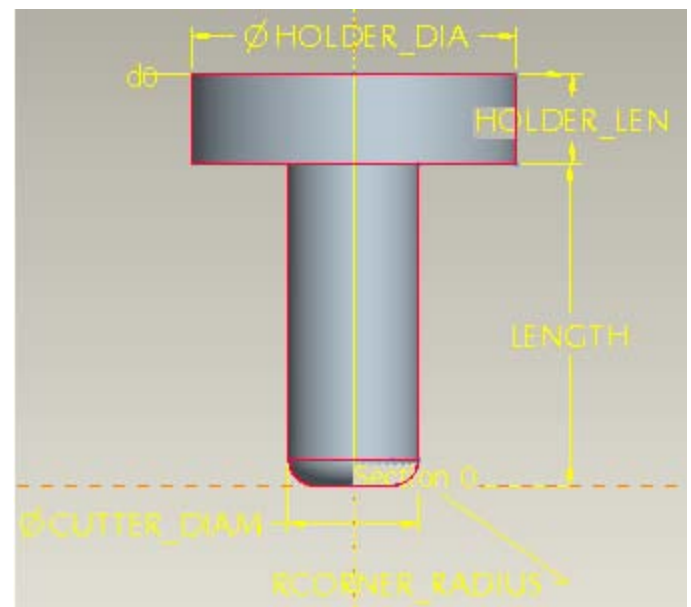

Establishing associativity between tool model's dimensions and NC Manufacturing tool parameters

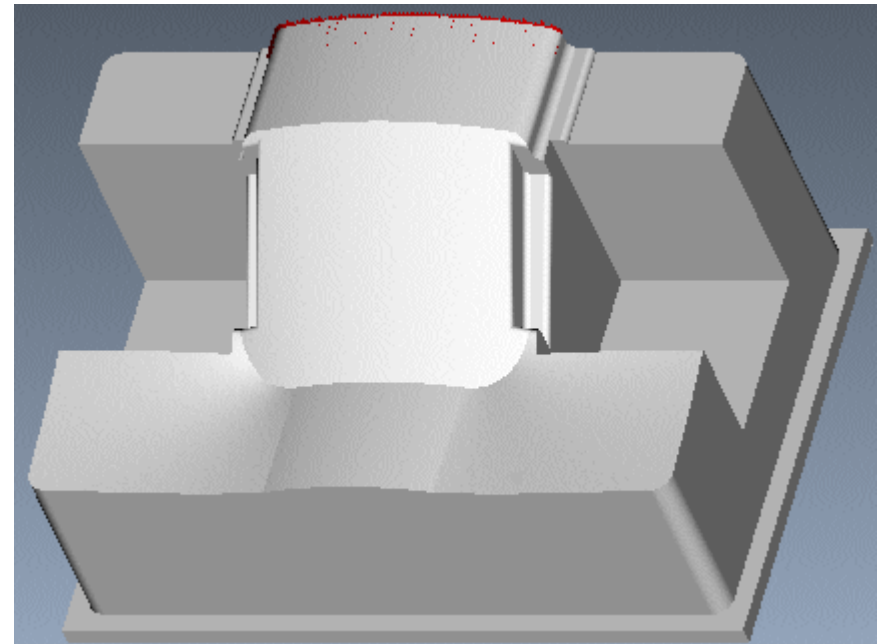

Detection of gouging while simulating with Solid tool

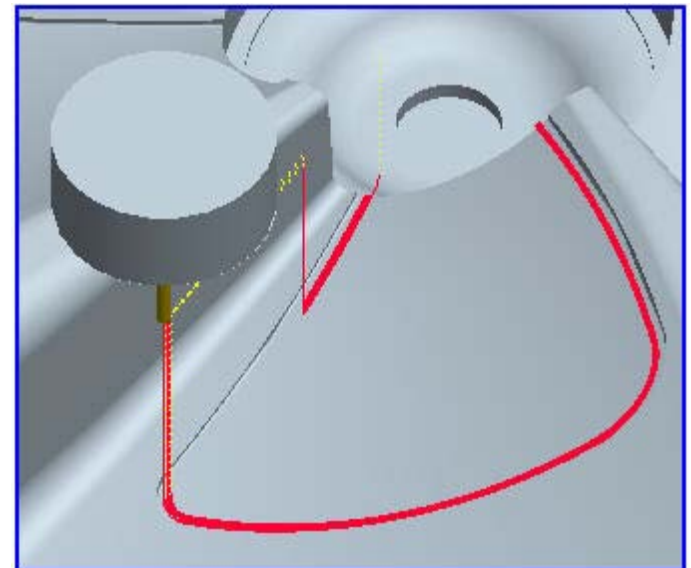

System uses holder geometry for automatic gouge avoidance

Process Manager

There are three major applications of Process Manager.

- Manufacturing Process Information
- Creation and Manipulation of Steps
- XML Template

The detail of topics covered in this chapter is as follows.

- How to get a printable list of tools used in the operation
- How to get a printable list all of the NC Sequences and their related information
- Creating a Holemaking Step in Process Manager
- Creating a 2-Axis Trajectory Milling Step in Process Manager
- Using Copy/Paste functionality to duplicate a step
- Creating a XML template from existing steps
- Using the XML template to create steps in another model

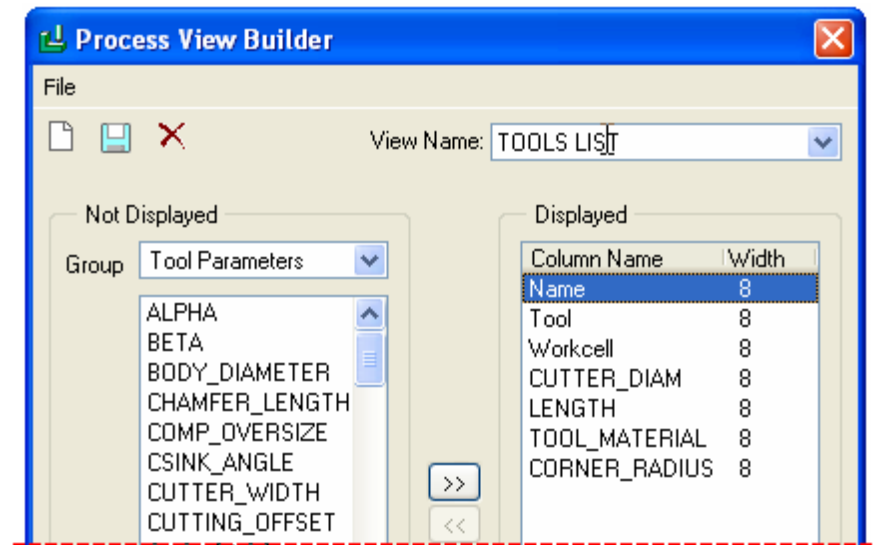

Building a view to list the tools and their parameters

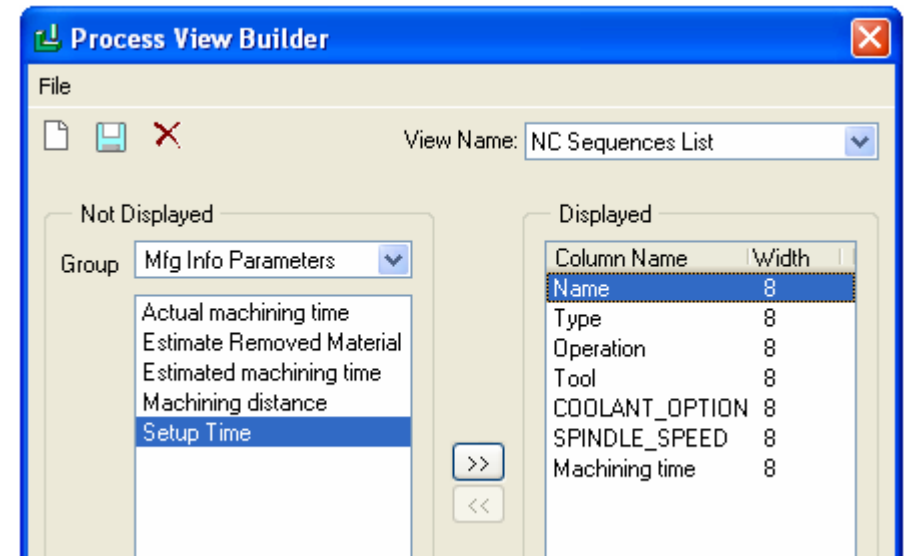

Building a view to list the NC Sequences and their related information

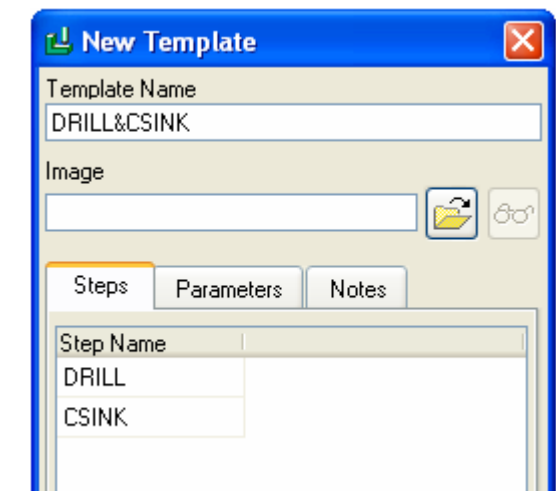

Creating XML template

MANUFACTURING PROCESS INFORMATION

Delivering information about manufacturing process and producing in-process documentation is very crucial for setting up of job and cutting tools on machine.

The topics covered are as follows.

- Creating a new drawing
- Associating the Manufacturing model's assembly to the drawing
- Defining tables and merging the cells
- Entering text and setting the width and height of the cells
- Defining repeat regions
- Entering the system and user defined parameters in the repeat regions
- Getting a list of parameters available for a tool and a NC Sequence
- Adding a filter to repeat region
- Inserting a new sheet
- Numeric formatting of parameters
- Inserting the different views of the model
- Changing display of a view to NO HIDDEN
- Changing the scale of sheet
- Displaying the toolpath in a drawing view
- Creating a PDF file of the drawing file

DETAILED TOOL INFORMATION	
TOOL NAME	BEM8
TOOL TYPE	MILLING
LENGTH UNITS	MILLIMETER
CUTTER DIAM	8.000

Creating Customized Tables

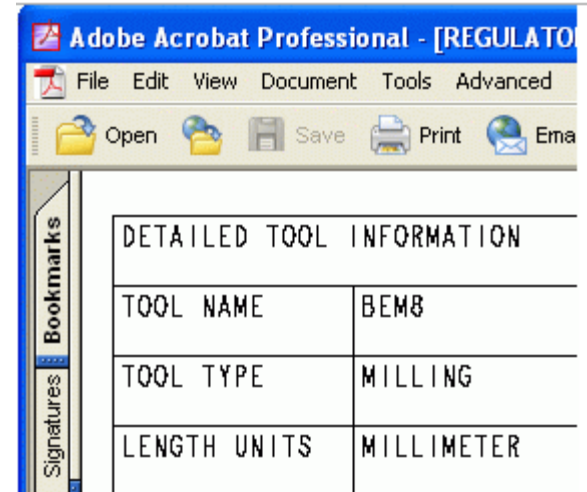

Printing the drawing to a PDF file

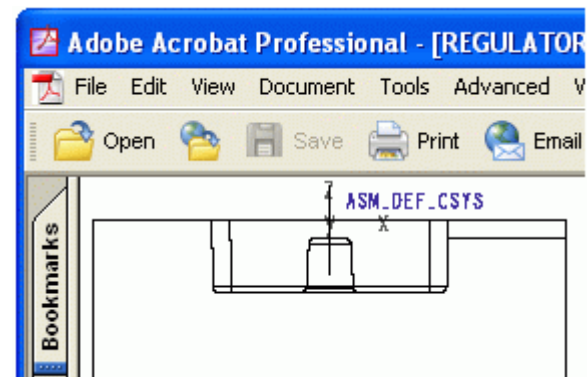

Inserting the views to setup job

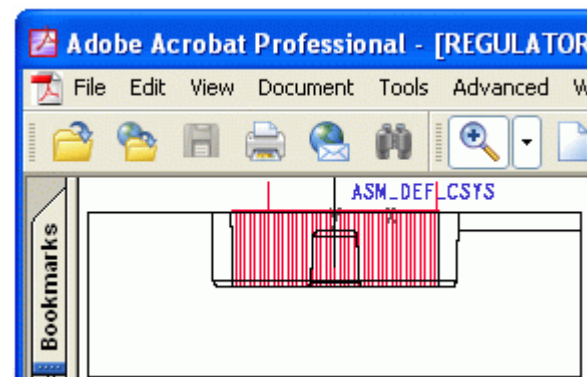

Displaying the toolpath in a drawing view

MANUFACTURING TEMPLATE

A manufacturing template file contains all the necessary setting which a user performs routinely while defining a manufacturing model.

The topics covered in this tutorial are as follows

- What is manufacturing template?
- Create a new operation
- Define new cutting tools
- Associating Feeds and Speeds data with tool
- Create a site file
- Utilizing the cutter Feed Speed data within NC Sequence
- Create a PPRINT table
- Create style state
- How to use the template for enhanced productivity

STEP_DEPTH	TOOL_ROUGH_AXIAL_DEPTH
STEP_OVER	TOOL_ROUGH_RADIAL_DEPTH

Creating Relations in Site File to extract Tool Cutting Data

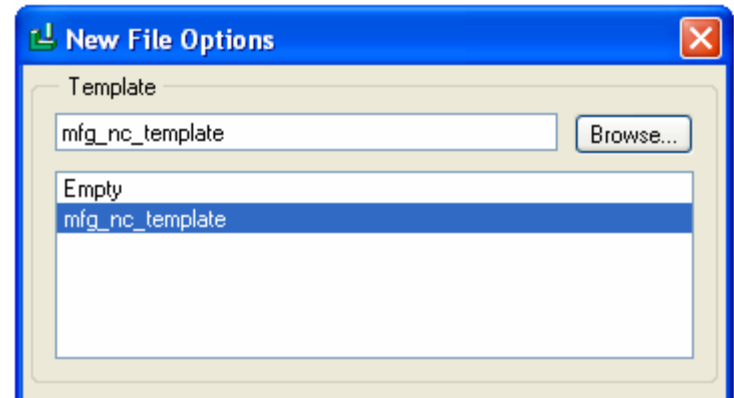

Using the custom defined template for enhanced productivity

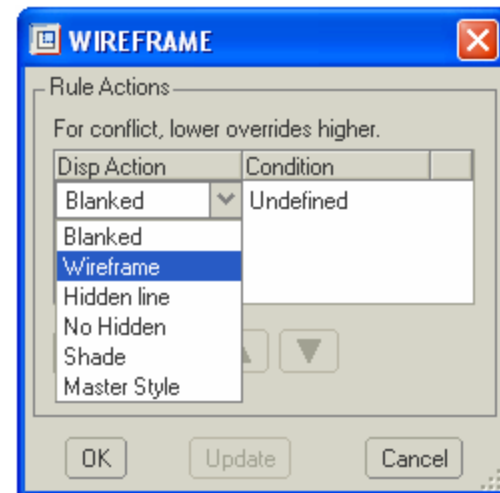

Defining Rules to Create Display Style

POST PROCESSING

The cutter location data (CL Data) produced by Pro/NC is meaningless to the machine controller. To transform the CL Data to useful controller acceptable instructions we need to post process it to machine control data (MCD) for a particular machine controller.

The topics covered are as follows.

- What is post processing
- Introduction to Option File Generator
- Introduction to GPOST
- Defining a new option file
- Configuring Pro/NC to select the option file automatically
- Modifying the option file settings to get the desired output
- Inserting program number at the beginning
- Inserting safety codes at the start of program.
- Inserting a blank before each address
- Changing the output order of addresses
- Changing the default format of addresses
- Changing the default behavior of radius output from IJK to R
- Inserting M30 at the end of MCD data
- Modify the option file to get the output for following drilling cycles
 1. Drilling
 2. Peck Drilling
 3. High Speed Peck Drilling
- Set the maximum federate to be output to tape file.
- Set the maximum spindle RPM to be output to tape file
- Set the option file to output operator messages to tape file
- Set the option file to output tool length compensation code G43
- Change the extension of tape file from .tap to .txt
- Set the maximum value of radius to be output to tape file
- Set the sequence number to be output with any specified increment

Pro/NC CYCLE	Required Format
CYCLE/DRILL	G81 X_ Y_ Z_ R_ F_
CYCLE/DEEP	G83 X_ Y_ Z_ R_ Q_ F_
CYCLE/BRKCHP	G73 X_ Y_ Z_ R_ Q_ F_

Customization of Post for Required Drilling Codes

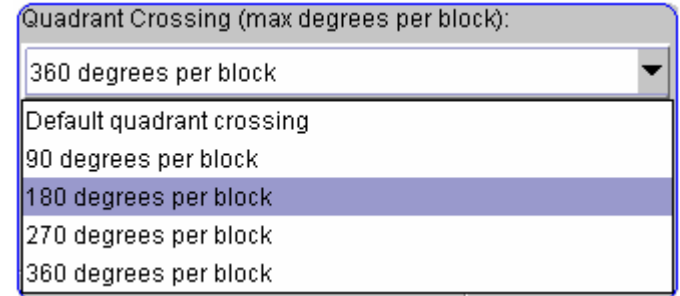

Customization of Post to get correct Radius Output

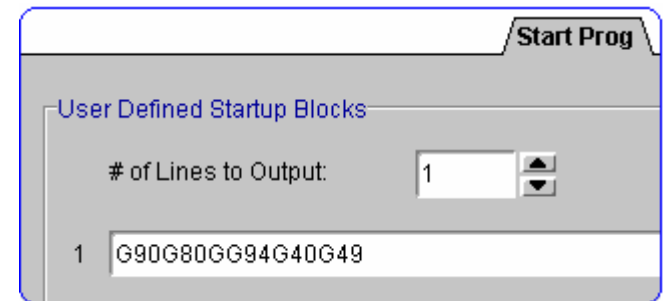

Specifying Safe Start up Block

```

%$
N1T5M6$
N2S3000M3$
N3G0X123.627Y-69.45$
N4Z5.$
N5Z-8.273$
N6G1Z-32.F1200.$
N7G3X106.041Y-47.298I103.758J-67.167$
N8G2X19.113Y-35.018I299.343J1634.943$
N9X12.96Y-32.129I21.15J-22.685$
N10G3X-33.357Y-10.861I-46.639J-100.856$
N11G1X-43.178Y-9.441$
N12G2X-99.666Y37.134I-33.353J60.017$
N13X-103.503Y59.927I-33.474J59.996$
N14G3X-123.523Y79.907I-123.503J59.907$
N15G1Z5.$
N16M5$
%$
$
  
```

Current Format

```

%
O0005
N1 G90G80G94G40G49
N2 M06 T05
N3 M03 S1000
N4 G00 X123.627 Y-69.45
N5 Z5.
N6 Z-8.273
N7 G01 Z-32. F1200.
N8 G03 X106.041 Y-47.298 R20.
N9 G02 X19.113 Y-35.018 R1693.31
N10 X12.96 Y-32.129 R12.5
N11 G03 X-33.357 Y-10.861 R90.969
N12 G01 X-43.178 Y-9.441
N13 G02 X-99.666 Y37.134 R70.149
N14 X-103.503 Y59.927 R70.029
N15 G03 X-123.523 Y79.907 R20.
N16 G01 Z5.
N17 M30
%
  
```

Required Format